Wall hung, fanflue, roomsealed, high efficiency gas boiler

Service manual

Riva Plus HE ERP

Models

G.C. Appl. No.

RIVA PLUS HE 24C ERP 47-583-41 COMBI BOILER

RIVA PLUS HE 28C ERP 47-583-42 COMBI BOILER

Leave this manual adjacent to the gas meter

Warning:



Service / repairs must be carried out, only by a qualified Gas Safety Registered Engineer, who will be responsible for the current Regulations for gas appliances.

Note:

After servicing, complete the relevant Service Interval Record section of the Benchmark Checklist of the user and installation manual.



TABLE OF CONTENTS

1 OVERALL INFORMATION	4	12 PRIMARY CIRCUIT PRESSURE SWITCH	30
1.1 Overall View	4	12.1 Function	30
1.2 Hydraulic diagram	4	12.2 Checks	30
2 GENERAL ACCESS AND EMPTYING HYDRAULIC CIRCUITS	5	12.3 Removal	30
2.1 Nomenclature	5	13 EXPANSION VESSEL AND TEMPERATURE-PRES-SURE GAUGE	31
2.2 Body panels	5	13.1 Function	31
2.3 Control panel	5	13.2 Checks	31
2.4 Access to the sealed chamber	6	13.3 Removal of the expansion vessel	31
2.5 Emptying the primary circuit	6	13.4 Removal of the temperature-pressure gauge	31
2.6 Emptying the d.h.w. circuit	6	14 D.H.W. FLOWMETER, FILTER AND FLOW LIMITER	32
3 DIAGRAMS	7	14.1 Function	32
3.1 Wiring diagram	7	14.2 Description and location of parts - (Figure 14.2)	32
3.2 Functional flow diagrams	8	14.3 Removal of the sensor	32
3.3 Circuit voltages	9	14.4 Checks	32
4 FAULT FINDING	10	14.5 Removal of the flow switch group and d.h.w. circuit filter	32
5 PRIMARY HEAT EXCHANGER	12	14.6 Flow limiter	33
5.1 Function	12	15 TEMPERATURE PROBE	34
5.2 Removal	12	15.1 Function	34
5.3 Cleaning	12	15.2 Checks	34
6 CONDENSING HEAT EXCHANGER	13	15.3 Removal of the c.h. temperature probe	34
6.1 Function	13	15.4 Removal of the d.h.w. temperature probe	34
6.2 Removal	13	16 BY-PASS VALVE	35
6.3 Cleaning	14	16.1 Function	35
7 D.H.W. HEAT EXCHANGER	15	16.2 Removal	35
7.1 Function	15	17 FAN AND AIR PRESSURE SENSOR	36
7.2 Removal	15	17.1 Function	36
8 PUMP	16	17.2 Checks	36
8.1 Function	16	17.3 Removal of the Fan	37
8.2 Checks	16	17.4 Removal of the Air pressure sensor	37
8.3 Removal pump	16	18 IGNITION AND DETECTION ELECTRODES	38
9 THREE WAY DIVERTER VALVE	17	18.1 Function	38
9.1 Function	17	18.2 Checks	38
9.2 Checks	17	18.3 Removal	38
9.3 Removal of the electric actuator	17	19 SAFETY THERMOSTAT	39
9.4 Removal of the tree way diverter valve	18	19.1 Function	39
9.5 Removal of the diverter group	18	19.2 Checks	39
10 ELECTRONIC CONTROL/IGNITION P.C.B.	19	19.3 Removal	39
10.1 Function	19	20 FLUE TEMPERATURE PROBE NTC	40
10.2 Selection and adjustment devices	19	20.1 Function	40
10.3 Checking the temperature	20	20.2 Checks	40
10.4 Operation lights	21	20.3 Removal	40
10.5 Setting the boiler control function modes	21	21 CONDENSATE TRAP	41
10.6 Useful output setting	21	21.1 Function	41
10.7 Re-ignition frequency setting	22	21.2 Removal	41
10.8 Ignition gas pressure adjustment	23	22 SHORT SPARE PARTS LIST	42
10.9 Setting the d.h.w. flowmeter operation mode	23		
10.10 Checks	24		
10.11 Removal of the electronic control p.c.b	24		
10.12 Thermal control in the  mode	26		
10.13 Thermal control in the  mode	26		
10.14 Ignition and control sequence	27		
11 MODULATING GAS VALVE	28		
11.1 Function	28		
11.2 Nomenclature of the parts	28		
11.3 Adjustment	28		
11.4 Checks	29		
11.5 Removal of the on-off operators coils	29		
11.6 Removal of the gas valve	29		

OVERALL INFORMATION

1 OVERALL INFORMATION

1.1 Overall View

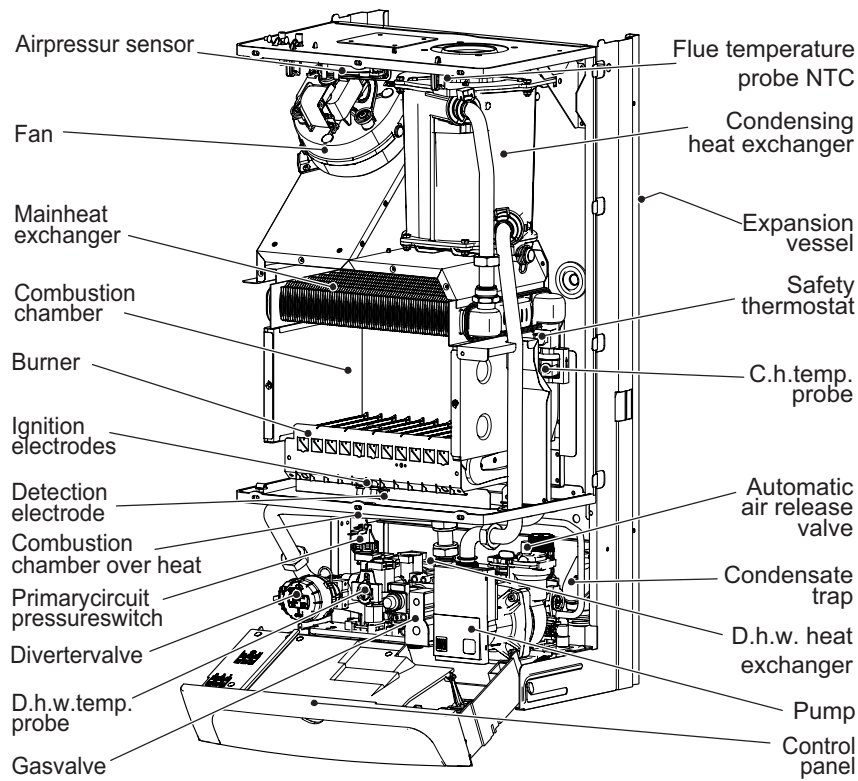

Figure 1.1

1.2 Hydraulic diagram

Central heating (c.h.) operation

Domestic hot water (d.h.w.) operation

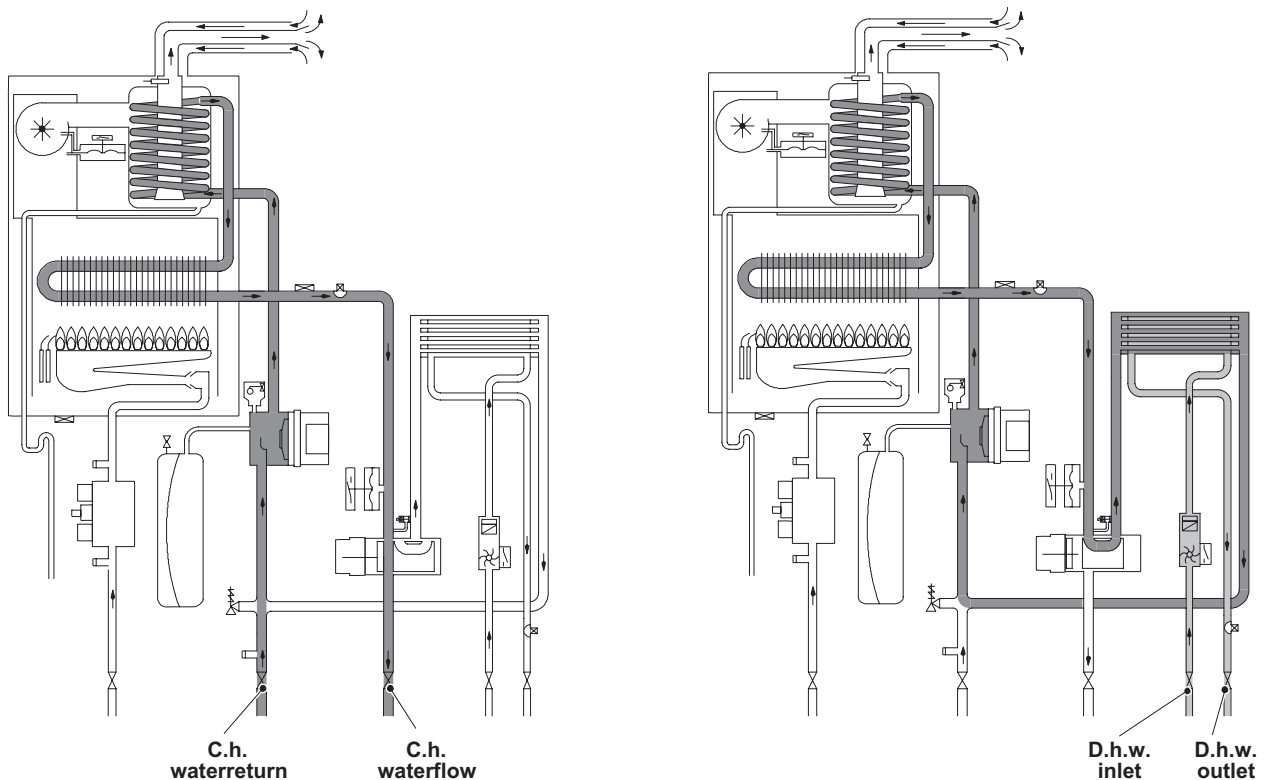

Figure 1.2

GENERAL ACCESS AND EMPTYING HYDRAULIC CIRCUITS

2 GENERAL ACCESS AND EMPTYING HYDRAULIC CIRCUITS

2.1 Nomenclature

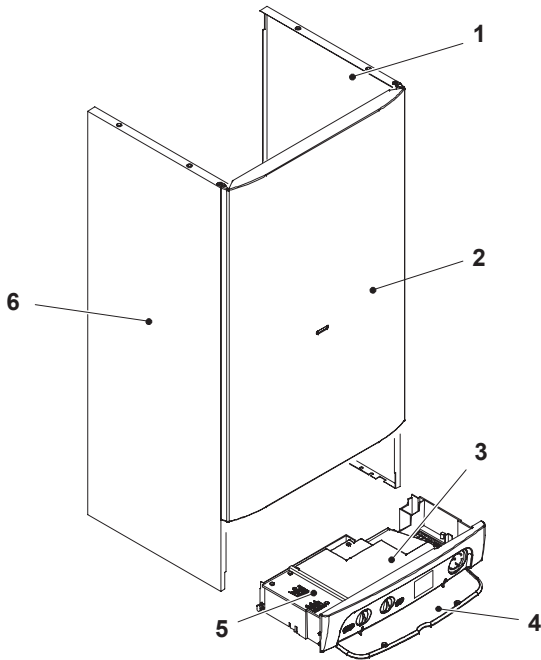

Figure 2.1

- 1 Right side panel
- 2 Front panel
- 3 Control panel lid
- 4 Control panel cover
- 5 Service panel
- 6 Left side panel

2.2 Body panels



Warning: isolate the boiler from the mains electricity supply before removing any covering or component.

For the most part of the check and maintenance operations it is necessary to remove one or more panels of the case.

The side panels can be removed only after the removal of the front panel.

To remove the front panel remove screws A (Figure 2.2), lift the panel and remove it.

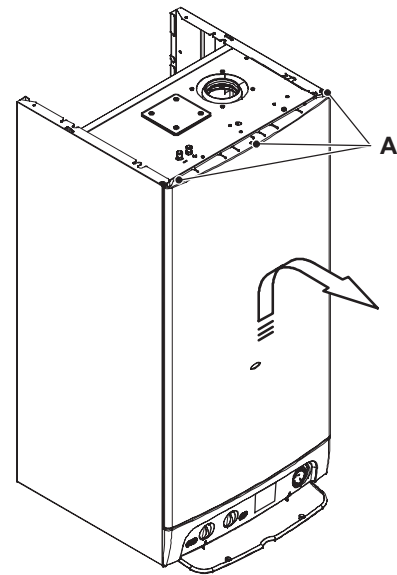

Figure 2.2

To remove the side panels loosen the screws B and C (Figure 2.3), bring the base of the panels away from the boiler and lift them, freeing them from the top hooks.

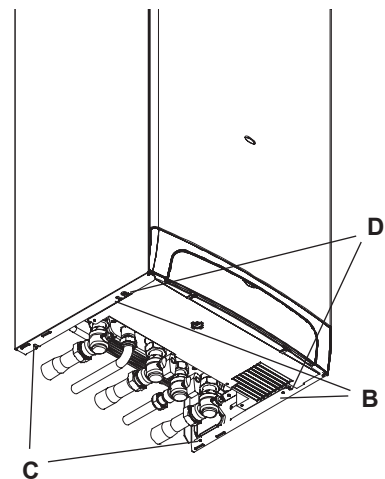

Figure 2.3 - Bottom view of the boiler

2.3 Control panel



Warning: isolate the boiler from the mains electricity supply before removing any covering or component.

To gain access to the parts located inside the control panel proceed as follows:

- 1 Remove the front panel of the case
- 2 Loosen the screws B and C (Figure 2.3).
- 3 Remove the screws D
- 4 Move the lower part of the side panels as indicated in Figure 2.4 and pull the control panel.

When completely pulled out, the panel can rotate 45° downwards to facilitate the service operations on the internal parts.

GENERAL ACCESS AND EMPTYING HYDRAULIC CIRCUITS

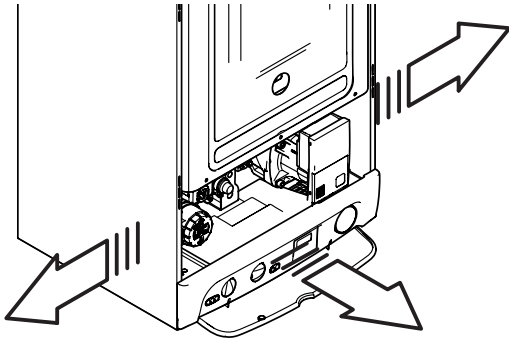

Figure 2.4

- 5 Remove the screws E and remove the service panel (Figure 2.5);
- 6 To gain access to the electronic regulation PCB remove the screws F and remove the control panel lid (Figure 2.5);

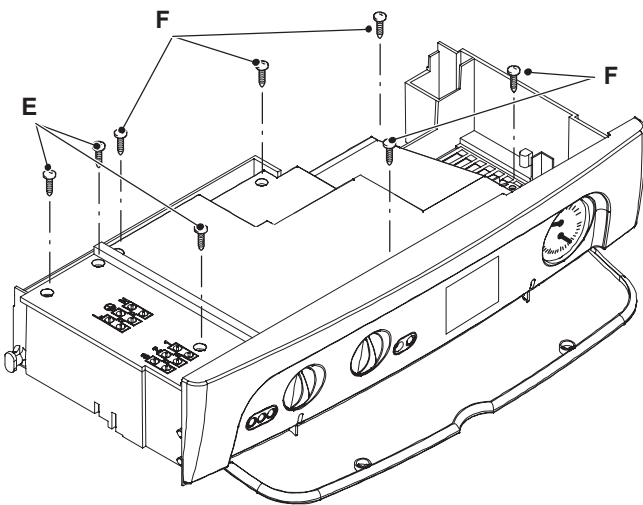

Figure 2.5

2.4 Access to the sealed chamber

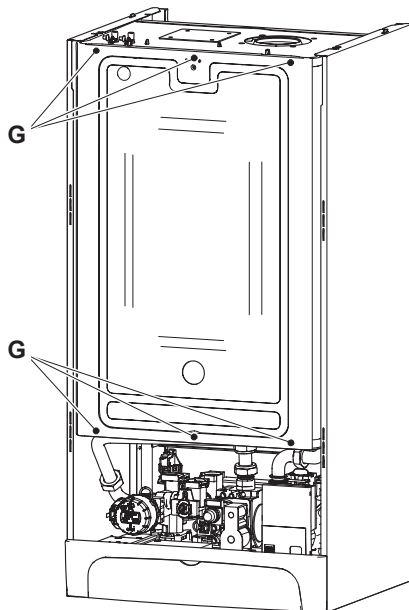

Figure 2.6

To gain access to the parts contained in the sealed chamber it is necessary to remove the lid of the sealed chamber. For this purpose, remove the front and side panels of the case, remove the screws G as indicated in Figure 2.6 and remove the lid.

2.5 Emptying the primary circuit

- 1 Close the c.h. circuit flow and return cocks.
- 2 Remove the front and right panels of the boiler.
- 3 Open the drain tap I (Figure 2.7) until the boiler is completely emptied.
- 4 Close drain tap again once the emptying has been completed.

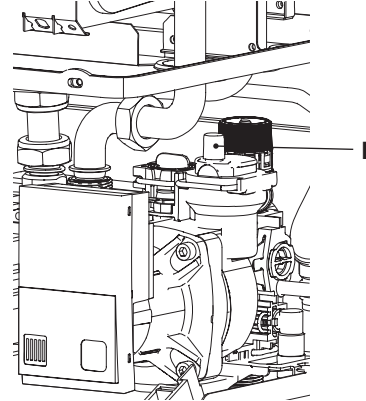

Figure 2.7

2.6 Emptying the d.h.w. circuit

- 5 Close the d.c.w. inlet cock;
- 6 Open one or more hot water taps until the boiler has been completely emptied.

DIAGRAMS

3 DIAGRAMS

3.1 Wiring diagram

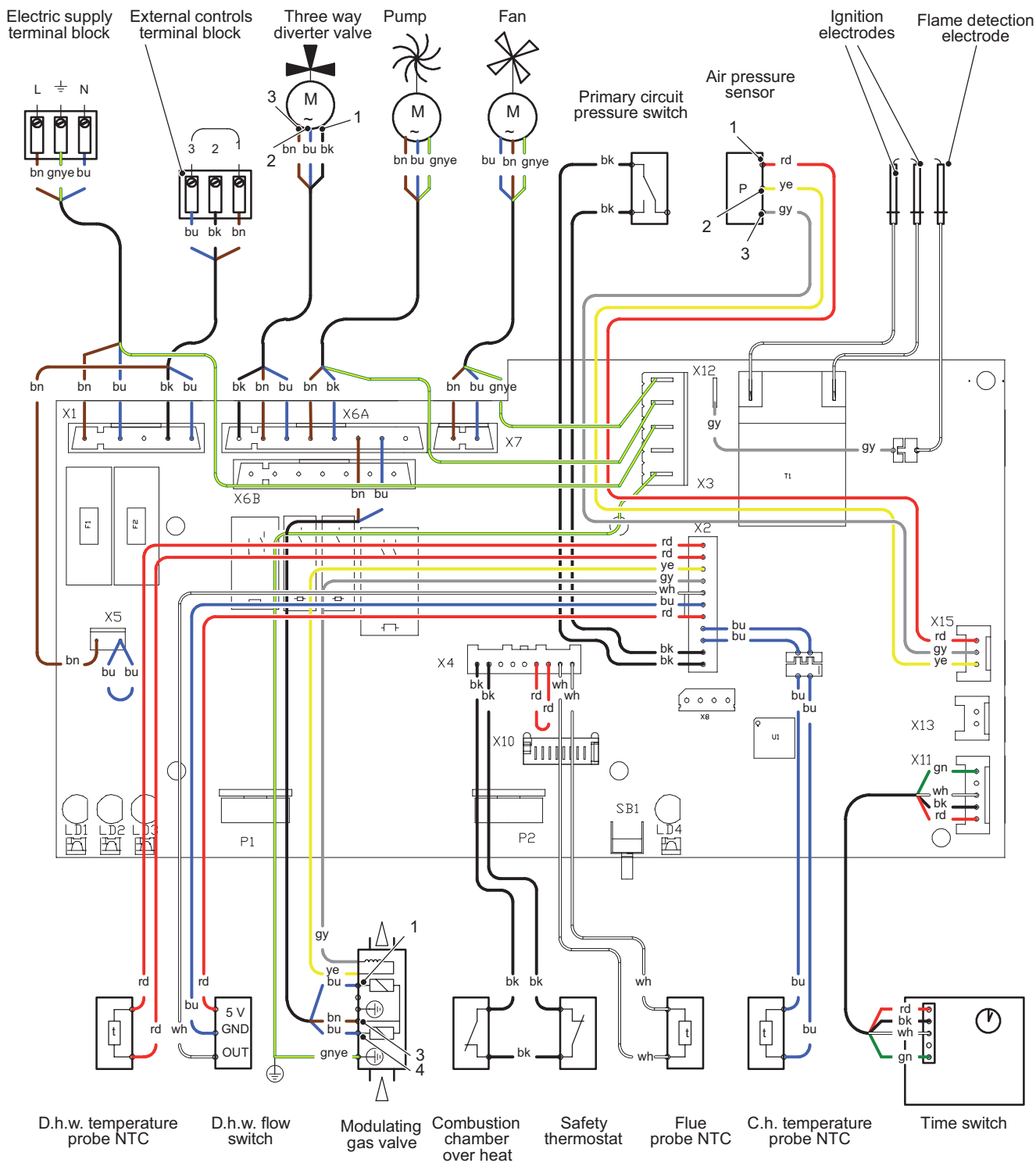

* = alternative
 bn = brown
 bu = blue
 bk = black
 wh = white
 rd = red
 gy = grey
 gn = green
 ye = yellow
 vt = violet
 og = orange
 gnye = green/yellow

Figure 3.1

DIAGRAMS

3.2 Functional flow diagrams

General layout

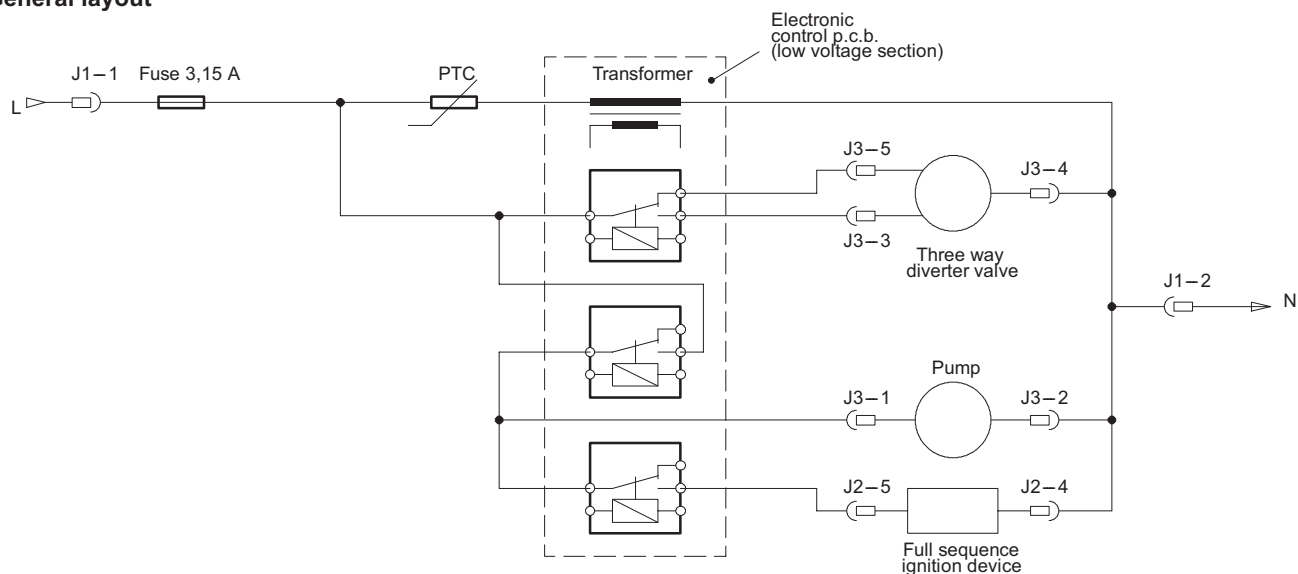

Heat request on d.h.w.

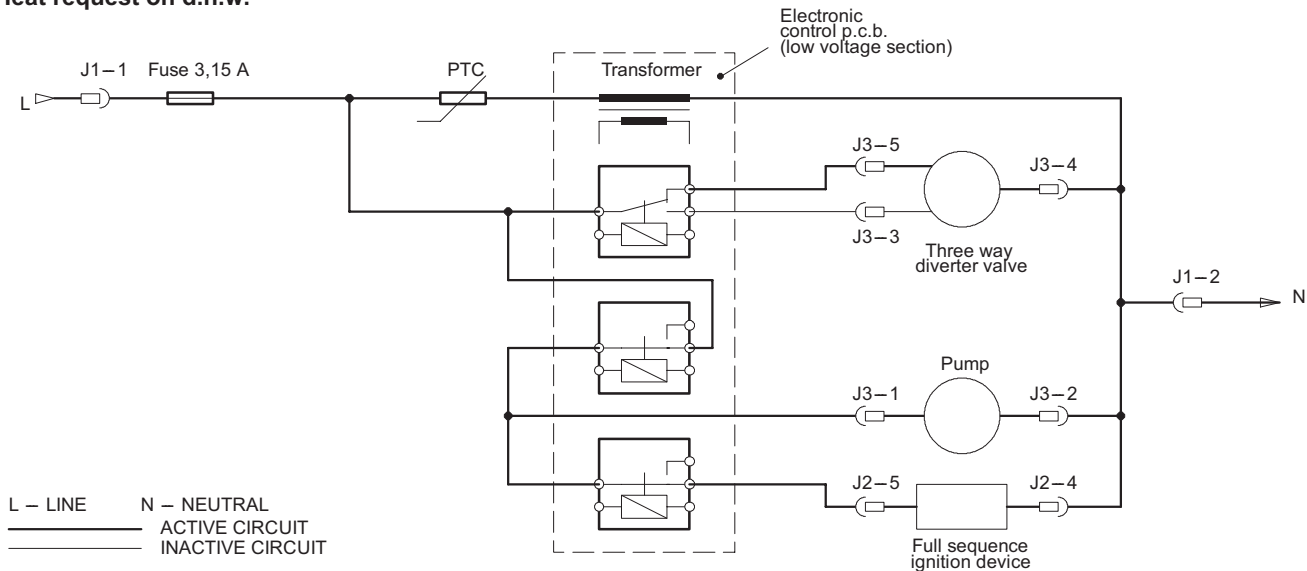

Heat request on c.h.

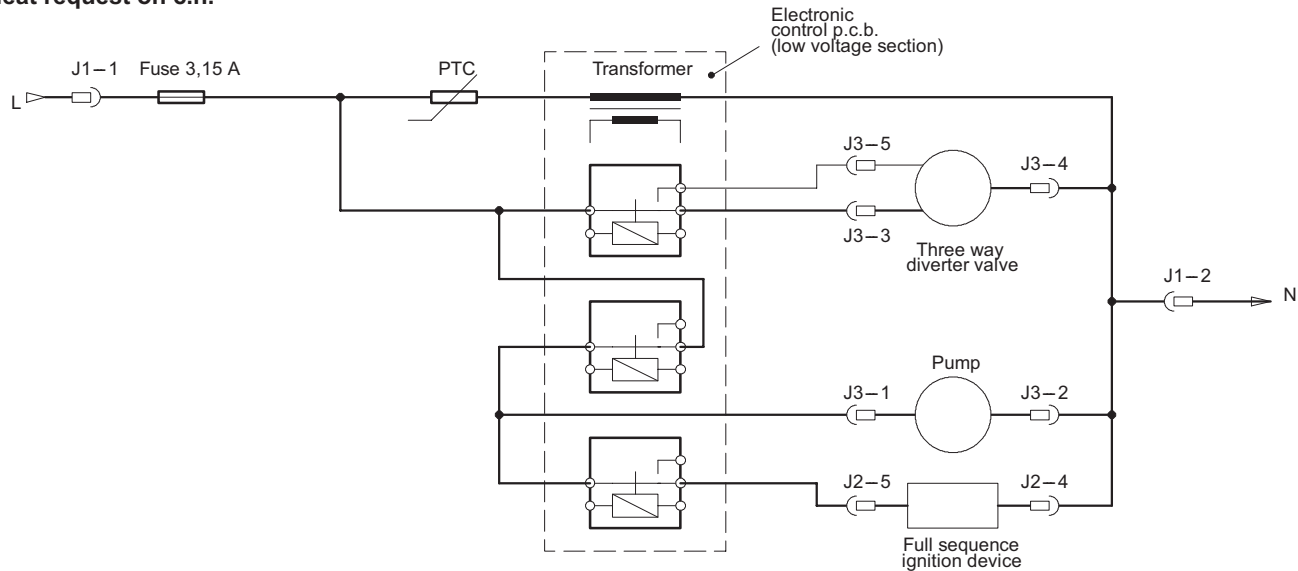

Figure 3.2

DIAGRAMS

3.3 Circuit voltages

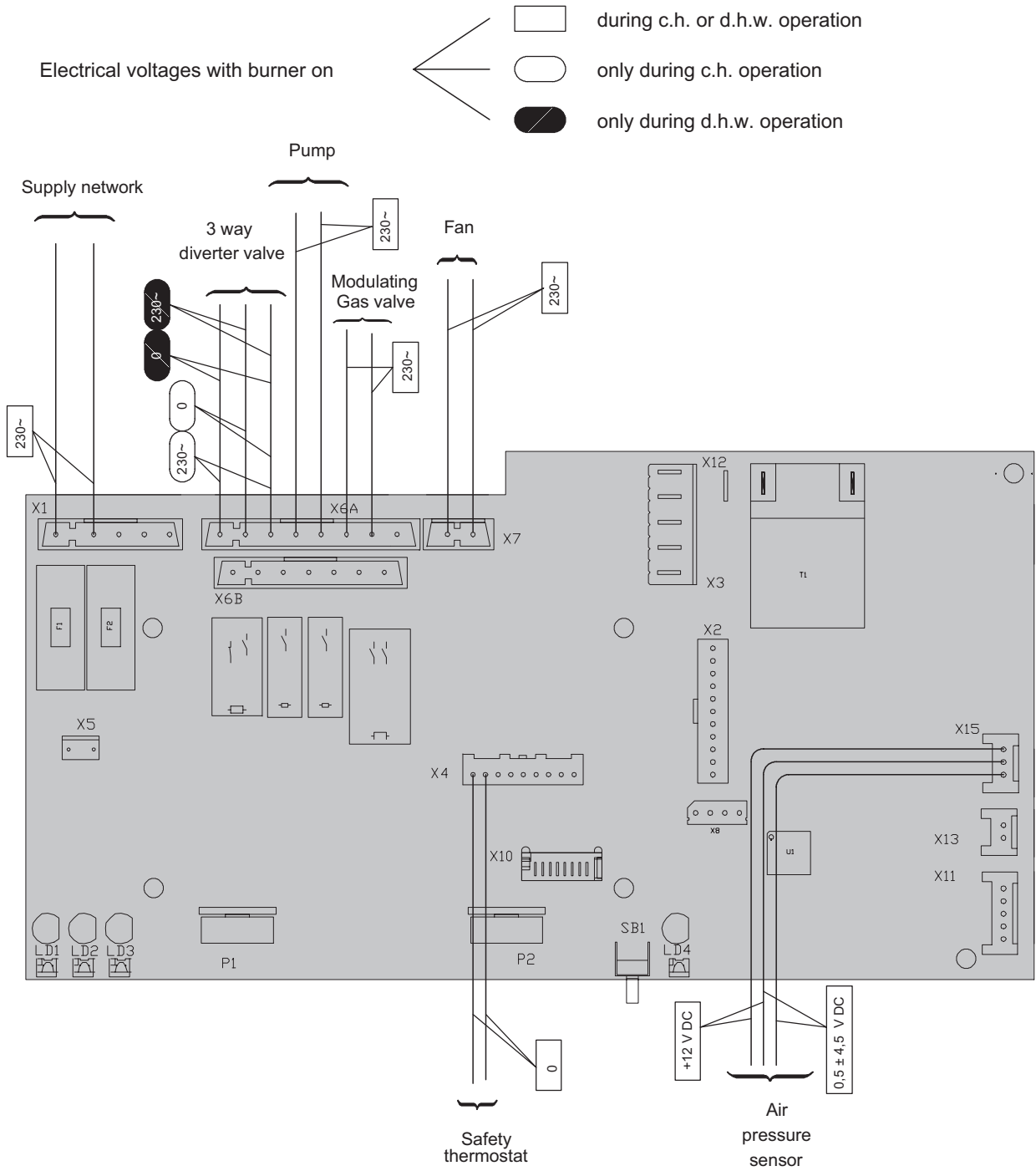

Figure 3.3

FAULT FINDING

4 FAULT FINDING

FAULT FINDING

Section of the manual → (note ref. in brackets)		Components to check																							
		(1)	(2)	(3)	21.1	(4)	7	8.2	9.2	10.10	11.4	12.2	14.5	15.2	16	17.2	18.2	19.2	20.1	(7)	(8)	-	-		
Lock – out signal lamp red	Defect →	Power supply line	■																						
		Gas supply line	■	■																					
NO		Flue pipes																							
		Condensate drain pipe and trap																							
		C.h. circuit																							
		D.h.w. circuit																							
		D.h.w. heat exchanger																							
		Pump																							
		Diverter valve																							
		D.h.w. flow switch																							
		Fuses (Electronic p.c.b.)																							
		Electronic p.c.b.																							
		Boiler settings																							
		Gas valve (on – off operators)																							
		Gas valve (modulating operator)	⑨																						
		Main circuit pressure switch																							
		D.h.w. filter																							
		Main circuit temp. probe																							
		D.h.w. temp. probe																							
		By – pass valve																							
		Fan																							
		Air pressure sensor																							
		Ignition electrode	■	■																					
		Detection electrode																							
		Safety thermostat	■	■																					
		Flue probe NTC																							
		Injectors	■																						
		Expansion vessel																							
		Safety valve																							
		Pressure gauge																							

FAULT FINDING

FAULT FINDING

Section of the manual → (note ref. in brackets)	Defect ↓	(1)	(2)	(3)	21.1	(4)	7	8.2	9.2	10.10	11.4	12.2	14.5	15.2	16	17.2	18.2	19.2	20.1	(7)	(8)	-				
		(1)	(2)	(3)	Condensate drain pipe and trap	C.h. circuit	D.h.w. circuit	D.h.w. heat exchanger	Pump	Diverter valve	D.h.w. flow switch	Fuses (Electronic p.c.b.) Electronic p.c.b.	Boiler settings	Gas valve (on-off operators) Gas valve (modulating operator)	Main circuit pressure switch	D.h.w. filter	Main circuit temp. probe D.h.w. temp. probe	By-pass valve	Fan	Air pressure sensor	Ignition electrode Detection electrode	Safety thermostat	Flue probe NTC	Injectors	Expansion vessel	Safety valve
Lock-out signal lamp red																										
The boiler does not supply d.h.w. (cold water from the tap). Regular operation in c/h mode even during a drawing off d.h.w.									■	■	■															
On c/h mode the temperature of the main circuit reaches 75°C and the c/h system does not heat. The boiler operates correctly on d.h.w. mode.									■																	
Incorrect modulation											■															
Noisy boiler				■												■										
The boiler operates correctly but the gas pressure to the burner remains at minimum.										■																
Poor d.h.w. temperature									■																	
Low d.h.w. flow rate																										
Water leaks from the safety valve during operation on c/h																									■	■
Water leaks from the safety valve when the boiler is off.																								■	■	

Note

Useful information can be obtained also from the optical indication given by the appliance operation lights (see section 10.4).

- 1 Check for 230V~ between line (L) and neutral (N). Verify the integrity of supply cable, plug and external fuses. Check the polarity of line and neutral connection
- 2 Verify the tightness of the gas supply pipe, the position of stop valves.

5 Check the gas pressure at the inlet test point of the gas valve (see sect. 11.3) with the boiler at rest and during operation and compare it with the values given on the installation booklet.

6 Check for soundness and absence of obstructions. Verify that the flue terminal is correctly installed (see clearances) and ensure that exhaust gas is not sucked back by the boiler.

7 Check for soundness of the circuit and verify its correct filling (see also installation manual).

5 A jammed by-pass could cause the over-heating of the main circuit and the intervention of the safety thermostat.

6 Check the **minimum** gas pressure at the outlet test point of the gas valve (see sect. 11.3) and compare it with the value given on the installation booklet.

7 Verify the cleanness of injectors.

8 Check the pressurization of the expansion vessel. Refer to the installation manual for proper values.

9 d.h.w. pressure too high or flow rate too high. If necessary insert a flow rate limiter (14.6)

PRIMARY HEAT EXCHANGER

5 PRIMARY HEAT EXCHANGER

5.1 Function

The primary heat exchanger A in Figure 5.1 has the function of transferring heat produced from combustion of the gas to the water circulating in it.

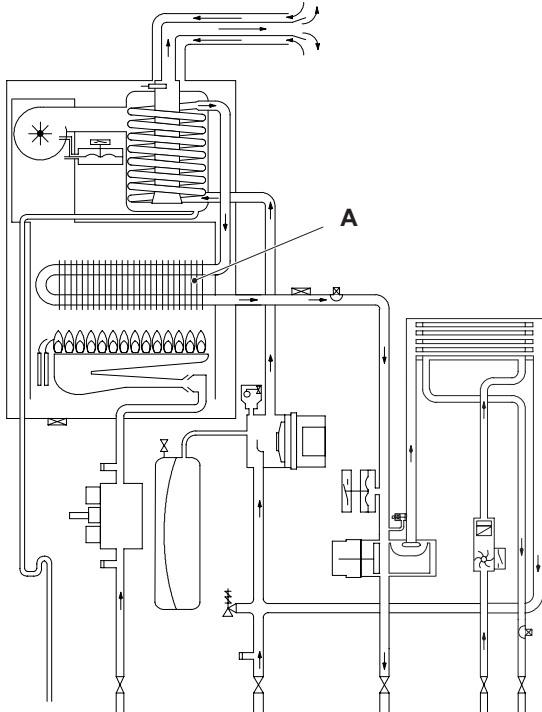

Figure 5.1

The hydraulic circuit is composed of 8 elliptical pipes connected in parallel (Figure 5.2).

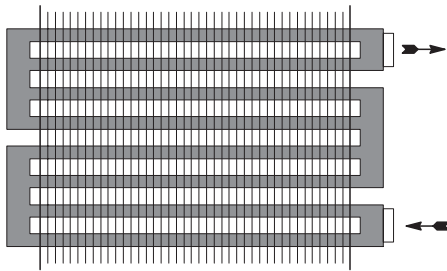

Figure 5.2

5.2 Removal



Warning: isolate the boiler from the mains electricity supply before removing any covering or component.

- 1 Remove the case panels and the sealed chamber lid (section "Body panels" page 5).
- 2 Empty the primary circuit of the boiler.
- 3 Remove the combustion chamber lid B by unscrewing the screws C (Figure 5.3).
- 4 Remove the screws D and the plate E.
- 5 Remove the clip F.
- 6 Loosen the connection G and slightly move the pipe H upwards.
- 7 Remove the clip I and the safety thermostat J and the c.h. temperature probe K. It is not necessary to disconnect it from the wiring.

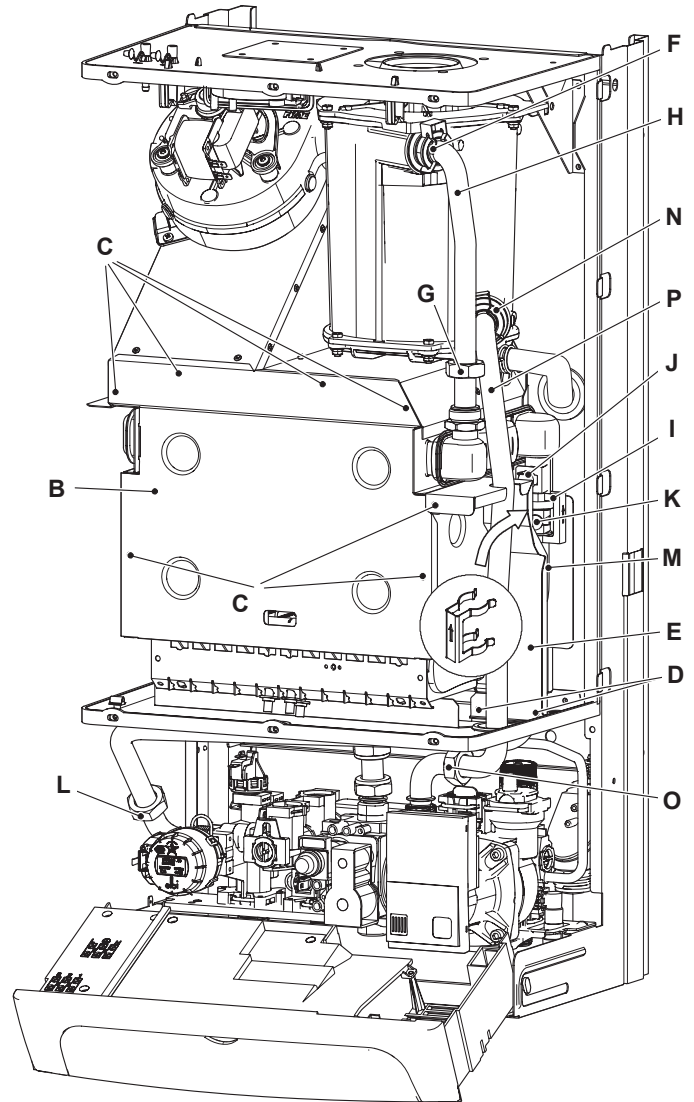

Figure 5.3

- 8 Loosen the connection L and move the pipe M downwards freeing it from the connection of the primary heat exchanger.
- 9 Remove the clip N.
- 10 Loosen the connection O.
- 11 Free the pipe P from the connection of the condensing heat exchanger; lift and rotate it towards right.
- 12 Remove the heat exchanger by sliding it forwards.
- 13 Reassemble the boiler carrying out the removal operations in reverse order. Fit the clip I with the arrow pointing upwards as illustrated in Figure 5.3.



IMPORTANT: do not force the connection G when tightening it.

5.3 Cleaning

If there are deposits of soot or dirt between the blades of the heat exchanger, clean with a brush or non-metallic bristle brush. In any case, avoid any actions that can damage the protective varnish with which the exchanger has been covered.



Warning: After cleaning or replacement as detailed above, if it deemed necessary to undertake a combustion analysis, refer to the appropriate chapter Maintenance of the installation instructions manual.

CONDENSING HEAT EXCHANGER

6 CONDENSING HEAT EXCHANGER

6.1 Function

The return water flows through the condensing heat exchanger A in Figure 6.1 and Figure 6.2.

By reducing the combustion products temperature, the latent heat of the vapour is transferred to the water circuit, allowing an extra gain of useful heat.

The condensed vapour is then drained through the condensate trap B and the draining pipe C.

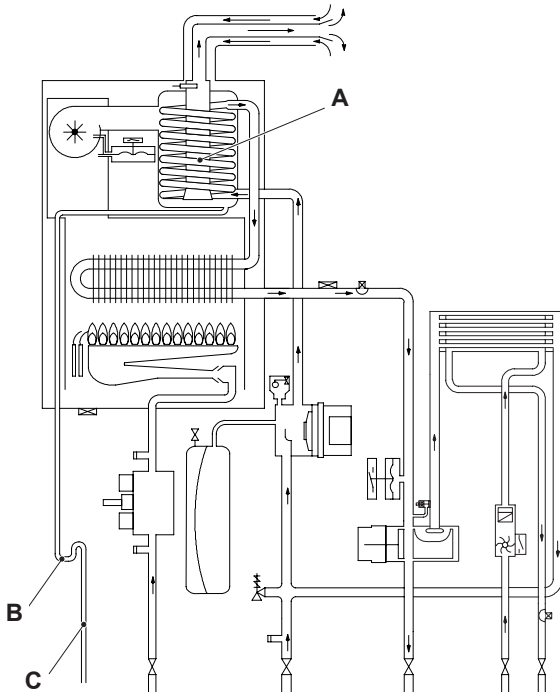

Figure 6.1

6.2 Removal



Warning: isolate the boiler from the mains electricity supply before removing any covering or component.

- 1 Remove the case panels and the sealed chamber lid (section "Body panels" page 5).
- 2 Empty the primary circuit of the boiler.
- 3 Remove the fan D in Figure 6.2 (see section "Removal of the Fan" page 37).
- 4 Disconnect the connectors of the flue temperature probe NTC E.
- 5 Remove the clip F.
- 6 Completely loosen the connection G and slightly move the pipe H upwards.
- 7 Remove the clip I.
- 8 Loosen the connection J.
- 9 Free the pipe K from the connection of the condensing heat exchanger; lift and rotate it towards right.
- 10 Using pliers, remove the spring L moving it to wards right and disconnect the rubber pipe M.
- 11 Rotate the exchanger as indicated by the arrow and remove it towards the front of the boiler.

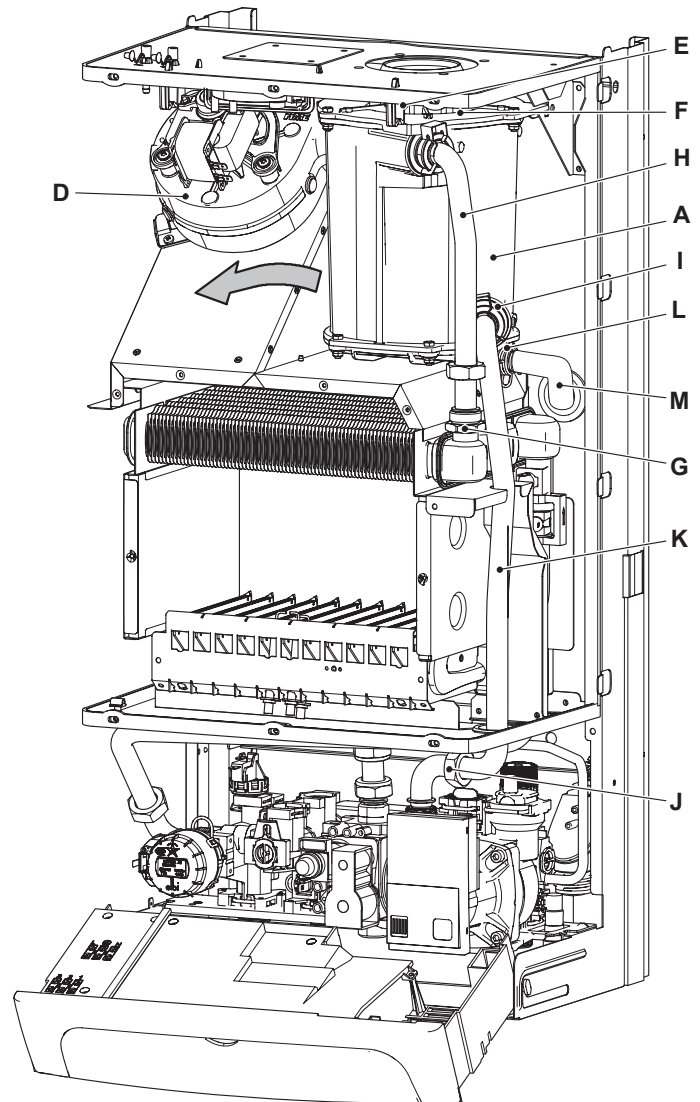

Figure 6.2

- 12 Reassemble the exchanger carrying out the removal operations in reverse order.



Warning: to lubricate the O-ring gaskets exclusively use a silicone base grease compatible to be in contact with foods and approved by the local water Authorities.

After reassembling ensure that the fan-exchanger and exchanger-elbow gaskets are correctly mounted and ensure a good sealing.



Warning: After cleaning or replacement as detailed above, if it deemed necessary to undertake a combustion analysis, refer to the appropriate chapter Maintenance of the installation instructions manual.

CONDENSING HEAT EXCHANGER

6.3 Cleaning

- 1 Using pliers, remove the spring L moving it to wards right and disconnect the rubber pipe M (Figure 6.3).
- 2 Unscrewing the screws N (Figure 6.3).
- 3 Remove the condensing heat exchange lid O (Figure 6.3) moving towards the front of the boiler.

If there are deposits of soot or dirt on the exchanger lid, clean with a brush or non-metallic bristle brush.

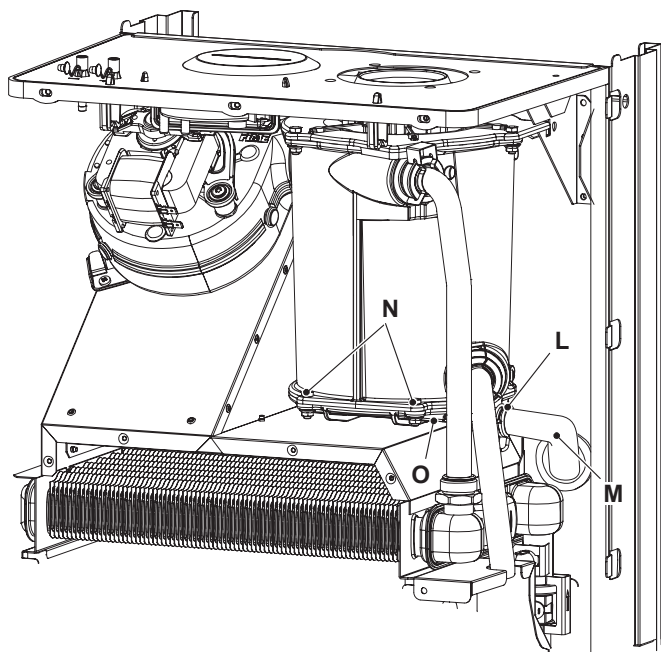

Figure 6.3

- 4 Reassemble the exchanger carrying out the removal operations in reverse order.



Warning: to lubricate the O-ring gaskets exclusively use a silicone base grease compatible to be in contact with foods and approved by the local water Authorities.



Warning: After cleaning or replacement as detailed above, if it deemed necessary to undertake a combustion analysis, refer to the appropriate chapter Maintenance of the installation instructions manual.

D.H.W. HEAT EXCHANGER

7 D.H.W. HEAT EXCHANGER

7.1 Function

The d.h.w heat exchanger A in Figure 7.1 and Fig. 4 allows the instantaneous transfer of heat from the primary hydraulic circuit to the water destined for d.h.w use.

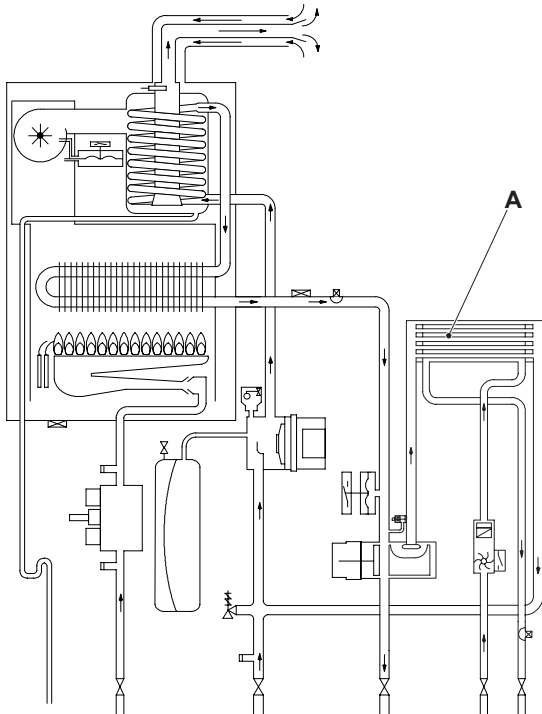
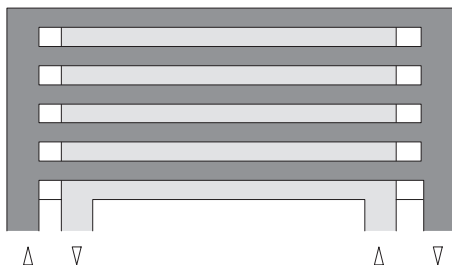

Figure 7.1

The schematic structure is shown in Figure 7.2.





-  Primary hydraulic circuit
-  Domestic hot water circuit

Figure 7.2

7.2 Removal



Warning: isolate the boiler from the mains electricity supply before removing any covering or component.

- 1 Remove the front and right hand side panels of the case.
- 2 Empty the primary circuit and the d.h.w circuit of the boiler.
- 3 Remove the pump B in Figure 7.3 (see section "Removal pump" page 16).
- 4 Remove the clip C and remove the primary circuit pressure switch D by lifting it upwards. It is not necessary to disconnect it from the wiring.
- 5 Remove the clip E and remove the electric actuator F by pulling it. It is not necessary to disconnect it from the wiring.

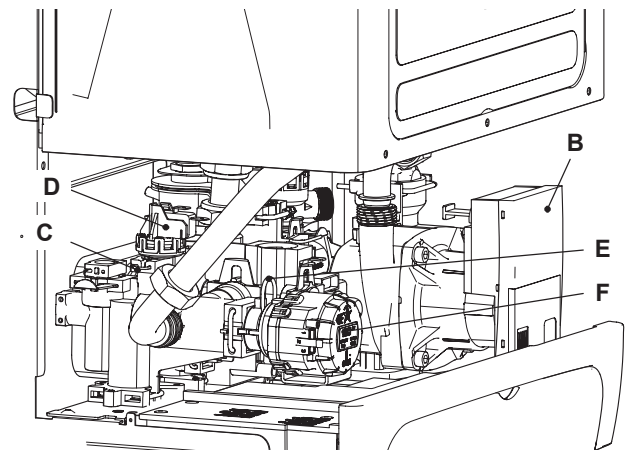

Figure 7.3

- 6 Completely unscrew the two Allen key screws G (Figure 7.4) which hold the exchanger to the plastic groups.

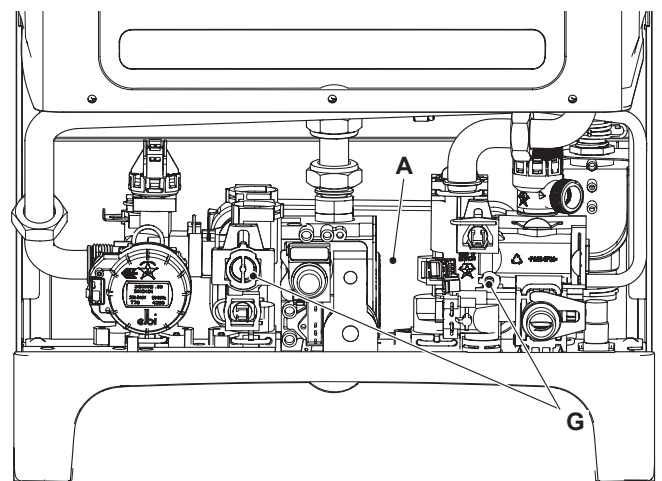

Figure 7.4

- 7 Move the exchanger towards the rear of the boiler and extract it.

Reassemble the d.h.w. heat exchanger carrying out the removal operations in the reverse order.



Warning: to lubricate the O-ring gaskets exclusively use a silicone base grease compatible to be in contact with foods and approved by the local water Authorities.



Warning: When reassembling the exchanger be sure to put the off center location/securing pin indicated in Figure 7.5 towards the left side of the boiler.

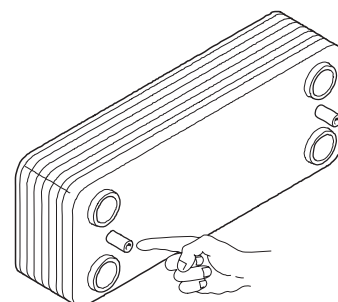

Figure 7.5

8 PUMP

8.1 Function

The pump A in Figure 8.1 and Figure 8.3 has the function of making the water in the main circuit circulate through the main heat exchanger, the condensing heat exchanger and therefore through the c.h. system (during the c.h. function) or through the secondary heat exchanger (during the d.h.w. function).

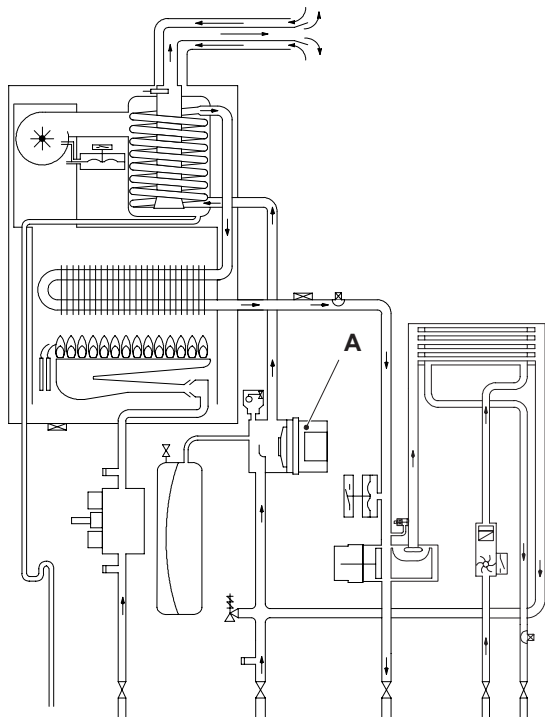

Figure 8.1

8.2 Checks



Warning: isolate the boiler from the mains electricity supply before removing any covering or component.

- ✓ Check that the pump is not seized and that the movement of the rotor is not subject to mechanical impediments.

The pump doesn't need.

Switch the boiler on.

The electronic control circuit provides automatically to unlock the pump to avoid seizing.

There is no inspection plug and it's not necessary to operate manually with screwdriver.

- ✓ Check that the impeller is integral with the rotor.

With the boiler off remove the front and right hand side case panels, lower the control panel and empty the primary circuit.

Remove the pump head by undoing the screws which hold it to the pump body and check that the impeller is firmly joined to the rotor.

8.3 Removal pump



Warning: isolate the boiler from the mains electricity supply before removing any covering or component.

- 1 Remove the case panels and the sealed chamber lid (section "Body panels" page 5).
- 2 Empty the primary circuit of the boiler.
- 3 Disconnect the connector B (Figure 8.3).
- 4 Loosen the connection D (Figure 8.2), and pull up and turn to the left the pipe E.
- 5 Remove the locking plate F (Figure 8.3).

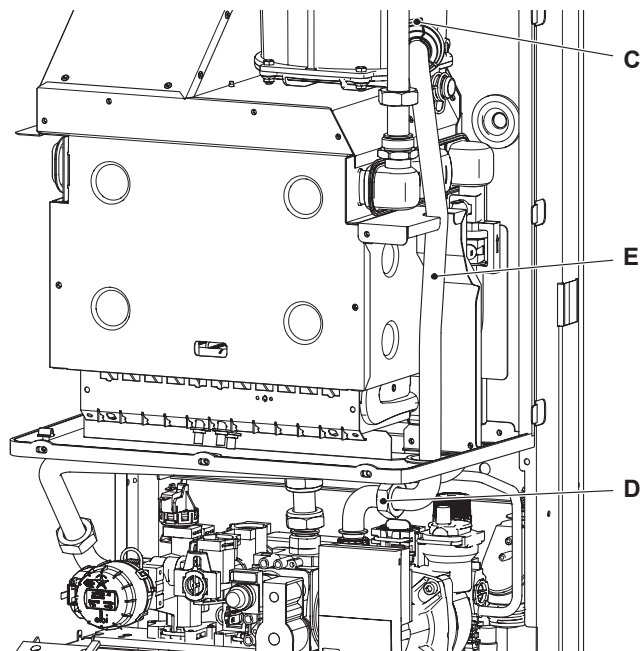

Figure 8.2

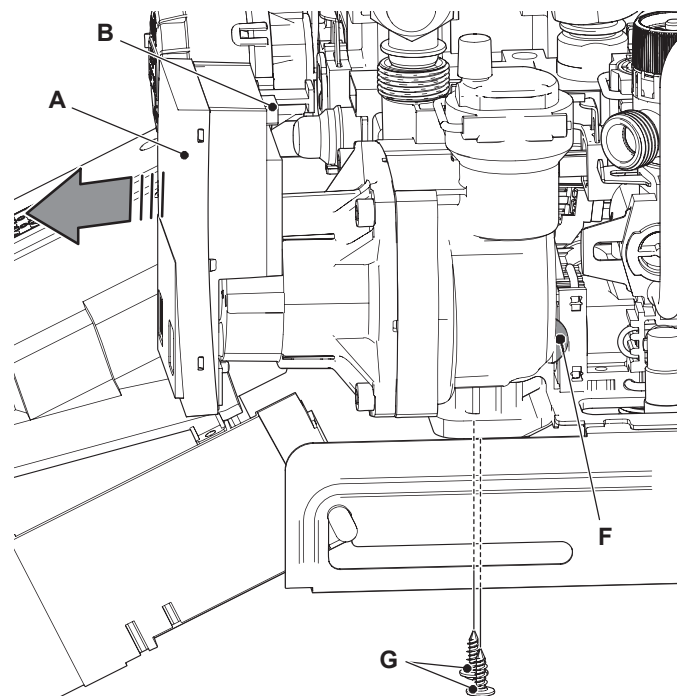

Figure 8.3

- 7 Unscrew the two screws G that hold the pump on the frame and remove the pump.

Reassemble the pump carrying out the removal operations in the reverse order. When reassembling the pump, check the correct location of the O-ring gasket in the inlet port of the pump that seals the connection between the pump and the return water group.

THREE WAY DIVERTER VALVE

9 THREE WAY DIVERTER VALVE

9.1 Function

The diverter valve A (Figure 9.1) has the function of modifying the hydraulic circuit of the boiler by means of an electric command given by the electronic control p.c.b. in order to send the water that exits the primary heat exchanger towards the c.h. system or towards the d.h.w. heat exchanger.

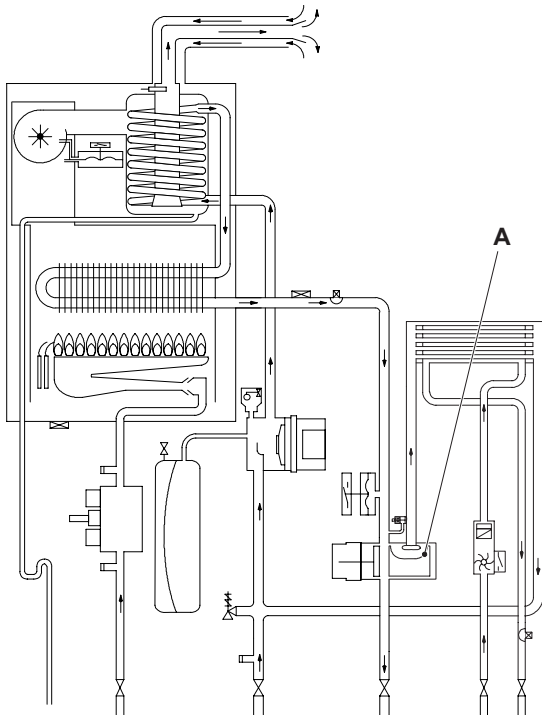

Figure 9.1

9.2 Checks



Warning: check the electrical continuity.

Figure 9.2 indicates the relationship between the electric command coming from the electronic control p.c.b. and the position of the actuator B (brass spindle) when the boiler operates in **d.h.w. mode**.

Figure 9.3 indicates the relationship between the electric command coming from the electronic control p.c.b. and the position of the actuator B (brass spindle) when the boiler operates in **c.h. mode**.

In both figures the relationship between the position of the actuator and the resistance of the motor windings (the motor must be disconnected from the wiring) is also given.

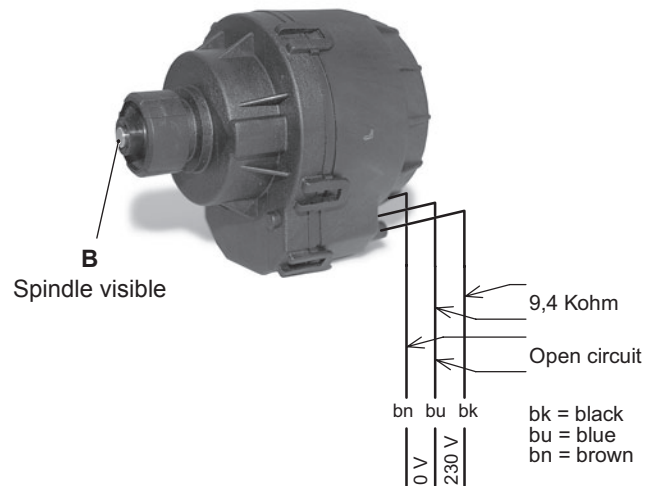

Figure 9.2 D.h.w. mode

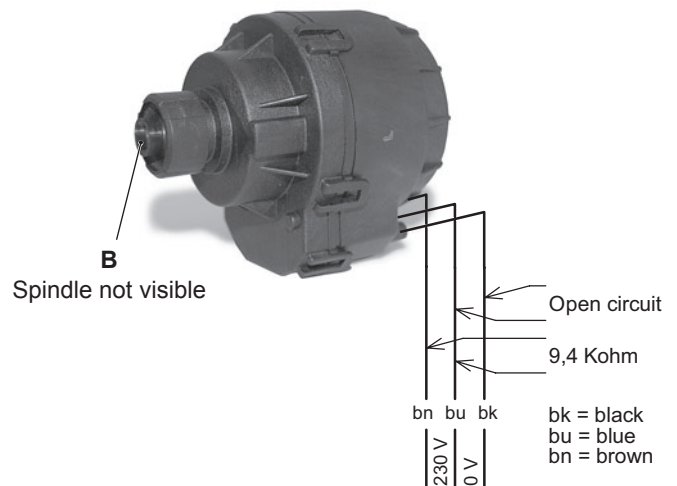

Figure 9.3 C.h. mode

9.3 Removal of the electric actuator



Warning: isolate the boiler from the mains electricity supply before removing any covering or component.

- 1 Remove the front case panel.
- 2 Disconnect the connectors C (Figure 9.4).
- 3 Remove the fixing spring D and remove the actuator B. Reassemble the actuator carrying out the removal operations in the reverse order. When reassembling the actuator, refer to Figure 9.2 or to the wiring diagram in section "Checks" page 17 for the correct wiring connection.

THREE WAY DIVERTER VALVE

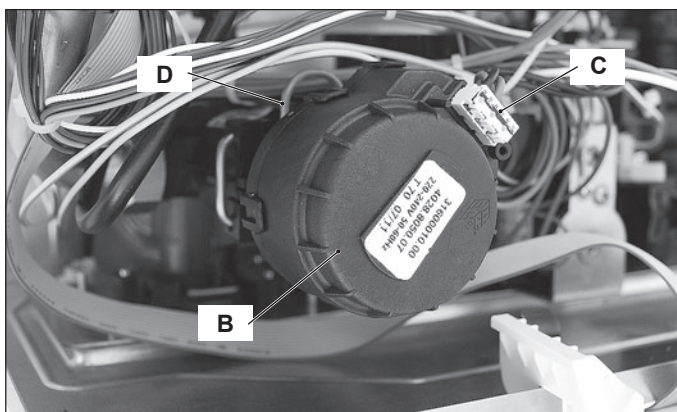

Figure 9.4

9.4 Removal of the tree way diverter valve

- 1 Remove the front and both side case panels.
- 2 Empty the primary circuit and the d.h.w circuit of the boiler.
- 3 Remove the electric actuator (section "Removal of the electric actuator" page 17).
- 4 Remove the fixing spring E (Figure 9.5)
- 5 Remove the tree way diverter valve F by levering with a screwdriver in as shown in Figure 9.5.

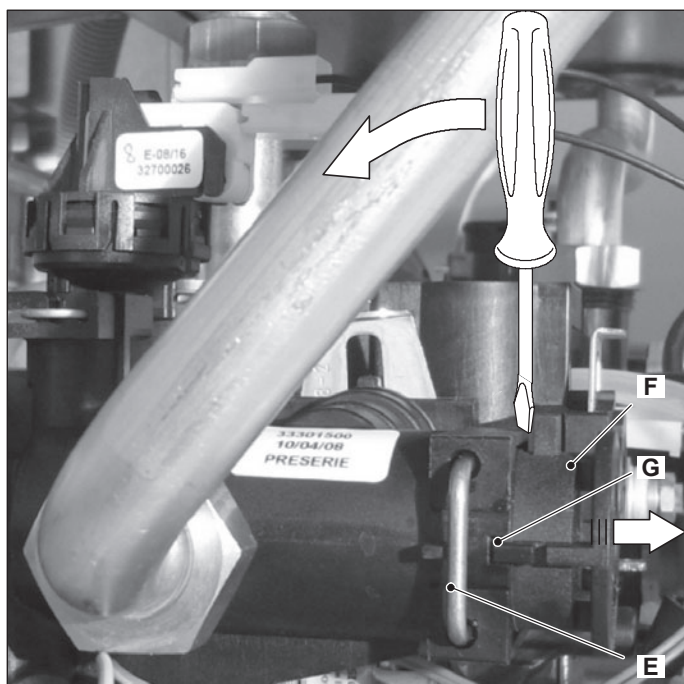



Figure 9.5

Reassemble the tree way diverter valve carrying out the removal operations in the reverse order.

 **Warning:** to lubricate the O-ring gaskets exclusively use a silicone base grease compatible to be in contact with foods and approved by the local water Authorities.

 **Warning:** When reassembling the tree way diverter valve be sure that the tree way diverter is correctly oriented by matching the reference G with the notch of the water group Figure 9.5.

9.5 Removal of the diverter group

- 1 Remove the front and both side case panels.
- 2 Empty the primary circuit and the d.h.w circuit of the boiler.
- 3 Remove the electric actuator (section "Removal of the electric actuator" page 17).
- 4 Remove the fixing spring H (Figure 9.6) and remove the primary circuit pressure switch I.



Figure 9.6

- 5 Disconnect d.h.w. temperature probe, respectively J (Figure 9.7).

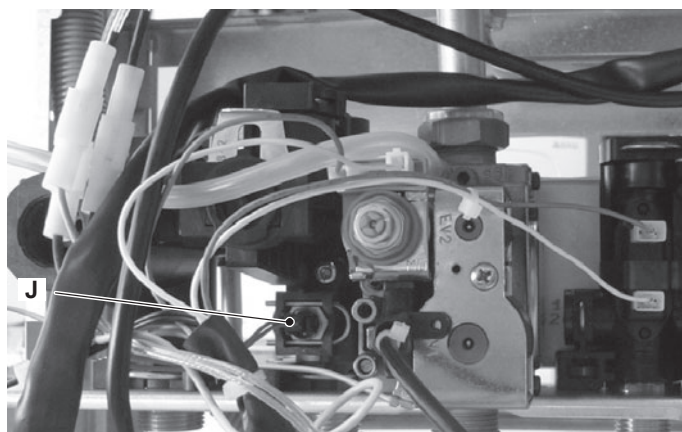



Figure 9.7

- 6 Unscrew the connector K (Figure 9.6), the c.h. flow connector and the d.h.w. outlet connector.
- 7 Remove the d.h.w. heat exchanger (section "Removal" page 15).
- 8 Unscrew the screws and remove the diverter group
- 9 Reassemble the diverter group carrying out the removal operations in the reverse order.

 **Warning:** to lubricate the O-ring gaskets exclusively use a silicone base grease compatible to be in contact with foods and approved by the local water Authorities.

10 ELECTRONIC CONTROL/IGNITION P.C.B.

10.1 Function

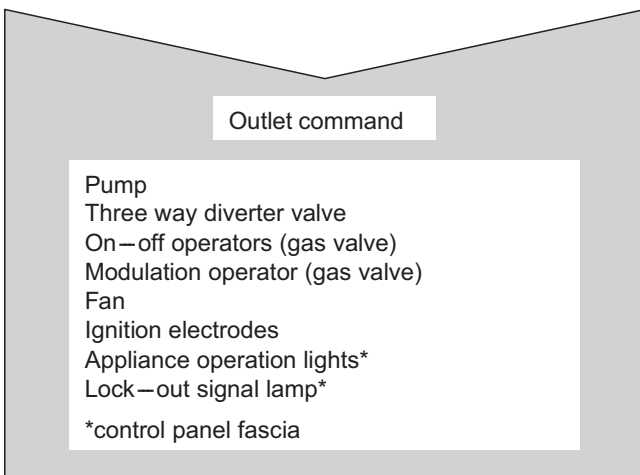
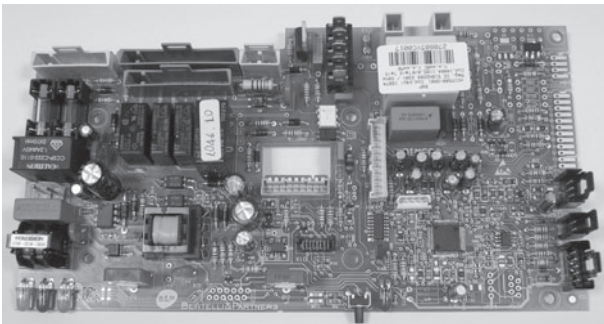
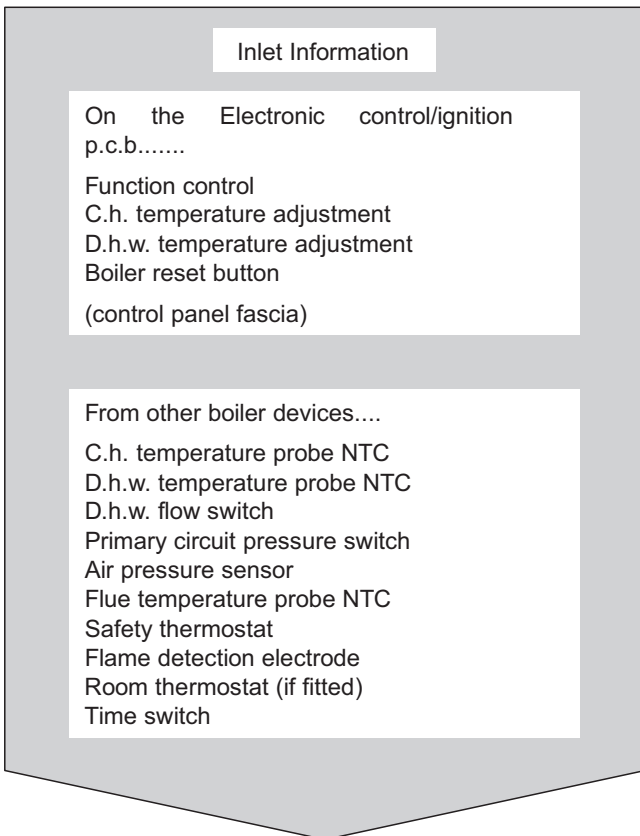

Figure 10.1

The fundamental function of the Electronic control/ignition p.c.b. is that of controlling the boiler in relation to the external needs (i.e. heating the dwelling or heating the water for d.h.w. use) and

operating in order to keep the temperature of the hydraulic circuits constant.

This is obviously possible within the useful power and maximum working temperature limits foreseen.

Generally, the Electronic control/ignition p.c.b. receives inlet information coming from the boiler (the sensors) or from the outside (knobs, room thermostat, etc.), processes it and consequently acts with outlet commands on other components of the boiler (Figure 10.1).

The Electronic control/ignition p.c.b. is also a full sequence ignition device and does a sequence of operations (ignition cycle) which lead to the ignition of the gas at the burner.

It checks the presence of the flame during the entire period in which it is activated, supplies the fan and checks its functioning by means of the signal coming from the air pressure sensor.

The Electronic control/ignition p.c.b. has a safety function and any incorrect interventions or tampering can result in conditions of dangerous functioning of the boiler.

The Electronic control/ignition p.c.b. can lock the functioning of the boiler (lock state) and stop its functioning up to the resetting intervention. The lock is signalled by the lighting of the lock-out signal lamp and the device can be reset only by using the boiler reset button placed on the control panel fascia.

Some components which are connected to the device can activate the lock state. The causes of a lock state could be:

- The intervention of the safety thermostat (overheat of the primary circuit).
- The intervention of the flue temperature probe (overheat of the combustion products).
- A fault on gas supply.
- Faulty ignition (faulty ignition electrodes, their wiring or connection).
- Faulty flame detection (faulty detection electrode, its wiring or connection).
- Gas injectors blocked.
- Faulty modulation gas valve (faulty on-off operators or not electrically supplied).
- Faulty Electronic control/ignition p.c.b..

Other components like the air pressure sensor can temporarily stop the ignition of the burner but allow its ignition when the cause of the intervention has stopped.

Figure 10.27 shows the sequence of the operations that are carried out at the start of every ignition cycle and during normal functioning.

10.2 Selection and adjustment devices

On the Electronic control/ignition p.c.b. several selection, adjustment and protection devices are located (Figure 10.2).

Some of these devices are directly accessible by the user (function control, temperature adjustment potentiometers etc.) others are accessible by removing the service panel or the control panel lid.

ELECTRONIC CONTROL/IGNITION P.C.B.

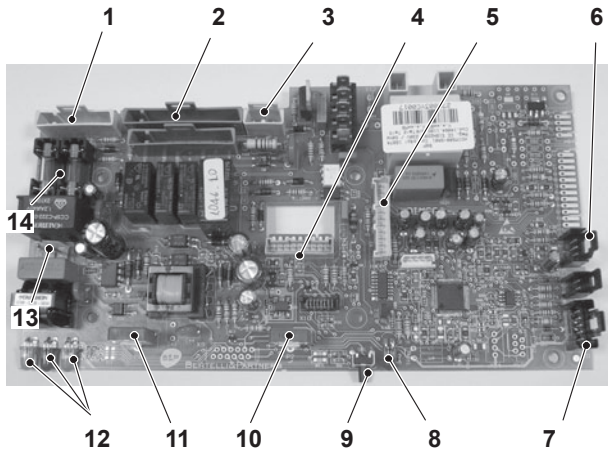

Figure 10.2

- 1 x1 connector
- 2 x6 connector
- 3 x7 connector
- 4 x4 connector
- 5 x2 connector
- 6 x15 connector
- 7 x11 connector
- 8 Lock-out signal lamp
- 9 Boiler reset button
- 10 Function control / C.h. temperature adjustment
- 11 D.h.w. temperature adjustment
- 12 Appliance operation lights
- 13 x8 connector
- 14 Fuse 3,15 A F

10.3 Checking the temperature

The Electronic control/ignition p.c.b. makes it possible to separately adjust the c.h. water flow temperature and d.h.w. outlet temperature.

The temperature of the water is converted into an electric signal by means of temperature probes.

The user, setting the desired temperature with the control panel knobs operates the variable elements (10 and 11 in Figure 10.2) of the electronic control p.c.b.

If the power requested is lower than 40% of the maximum power output then control is achieved by switching ON the burner at minimum power, then switching OFF (ON/OFF function). If the power requested is higher, then the burner is switched ON at maximum power and will control by modulating to 40% of the maximum power output.

During the c.h. operation (Figure 10.3), the signal coming from the c.h. temperature probe is compared to the signal given by the control panel through the adjustment made by the user (knob ). The result of such a comparison operates the modulation of the gas valve, consequently changing the useful output of the boiler.

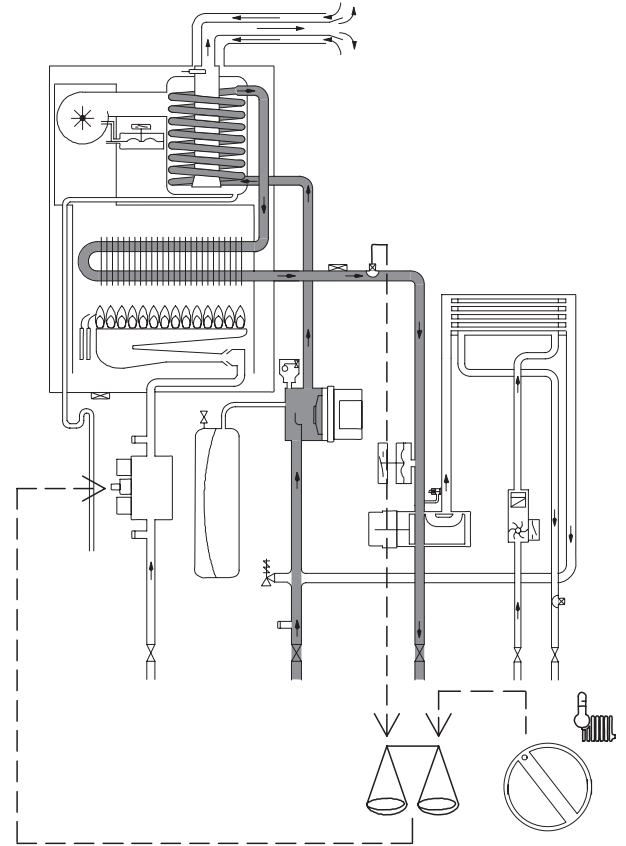



Figure 10.3

When the boiler functions in d.h.w. (Figure 10.4), the signal coming from the d.h.w. temperature probe is compared with the signal given by the control panel through the adjustment made by the user (knob ).

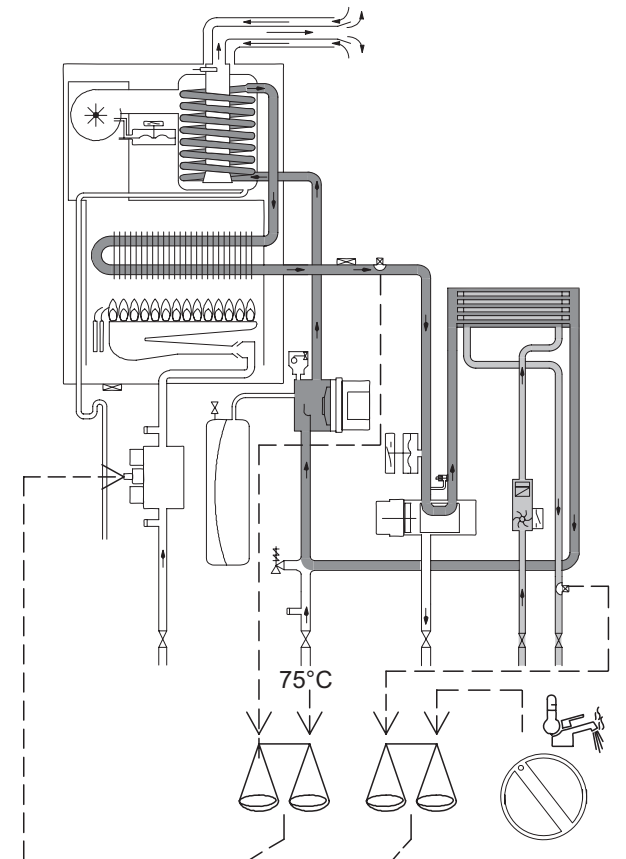

Figure 10.4

ELECTRONIC CONTROL/IGNITION P.C.B.

Normally, the result of the comparison between these two signals directly operates the adjustment elements of the gas valve modulation device, adjusting the useful output generated in order to stabilize the temperature of the exiting water.

If during the d.h.w. mode operation, the temperature of the primary circuit goes over 75°C, the useful output is automatically reduced so that the primary circuit cannot reach excessive temperatures.



The control sequences in ❄️ function and in ☀️ function are illustrated in detail in sections 10.2 and 10.3.

10.4 Operation lights

The Electronic control/ignition p.c.b. is provided with three lamps (L.E.D. indicators) 12 in Figure 10.2 that give optical information during the operation of the boiler.

The green lamp on the left gives information whether the boiler is in stand-by mode or during the normal operation of the boiler.

The following table gives the relationship between the lamp indication and its meaning.

 <p>A short pulse every 4 seconds</p>	Boiler in stand-by condition. (function control in ⏻ position). Anti-freeze system active.
 <p>1 second ON 1second OFF</p>	Boiler ON condition (function control in ❄️ or ☀️ position)

With the boiler switched ON (❄️ or ☀️) all the lamps (12 in Figure 10.2) are activated.

The following table gives the relationship between each of the possible lamp combinations and their meaning.

□ □ □	
☀️ ○ ○	Normally operating boiler (see the previous table for details)
☀️ ○ ☀️	C.h. operation
☾ ○ ☾	D.h.w. operation
☀️ ☀️ ○	Frost protect operation
○ ○ ☀️	D.h.w. operation Excessive temperature on primary circuit
○ ☀️ ☀️	Faulty c.h. temperature probe NTC
○ ☀️ ●	Faulty d.h.w temperature probe NTC
● ☀️ ○	Faulty flue temperature probe NTC
☀️ ● ○	Faulty primary circuit (no water or low c.h. pressure)
☾ ☾ ●	Faulty primary circuit (absence of flow)

□ □ □	
☀️ ☀️ ●	Faulty air pressure sensor
☀️ ● ☀️	Lack of burner ignition (no ignition signal from the full sequence ignition device)
● ☀️ ☀️	Safety thermostat lock out
● ● ☀️	Flue temperature probe NTC lock out
☀️ ☀️ ☀️	Flame detection error
○ ☀️ ○	Flame detection error
○ ○ ○	Lack of power supply or faulty electronic control p.c.b. *
○	Lamp OFF
●	Lamp ON
☀️	Flashing lamp, alone or simultaneously with another lamp
☾	Flashing lamp, alternate with another lamp

* These conditions are normal only for a short time when the power supply is applied to the boiler.
If permanent they indicate a faulty p.c.b.

10.5 Setting the boiler control function modes

It is possible to select the various boiler control function modes by using the function selector knob A and the d.h.w. temperature control knob B (Figure 10.5).

During the function modes setting, the boiler does not operate.

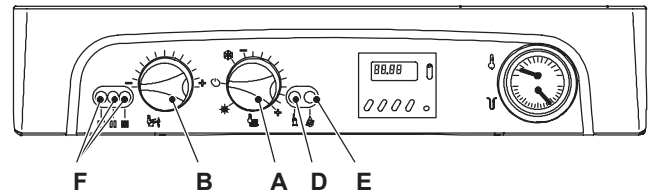

Figure 10.5

10.6 Useful output setting

To set the useful output proceed as follows:

- 1 Remove the front panel of the case.
- 2 Take off the lid of the sealed chamber.
- 3 Switch on the appliance at the mains isolating spur.
- 4 Turn the boiler OFF positioning the function selector A as indicated in Figure 10.6.

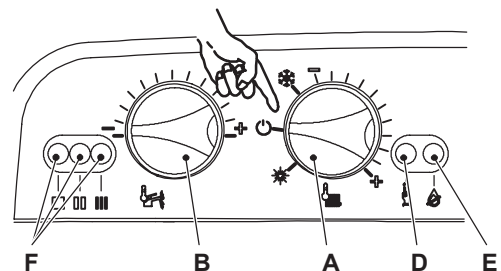

Figure 10.6

- 5 Disconnect the electrical connectors C of the c.h. temperature probe NTC in Figure 10.7.

ELECTRONIC CONTROL/IGNITION P.C.B.

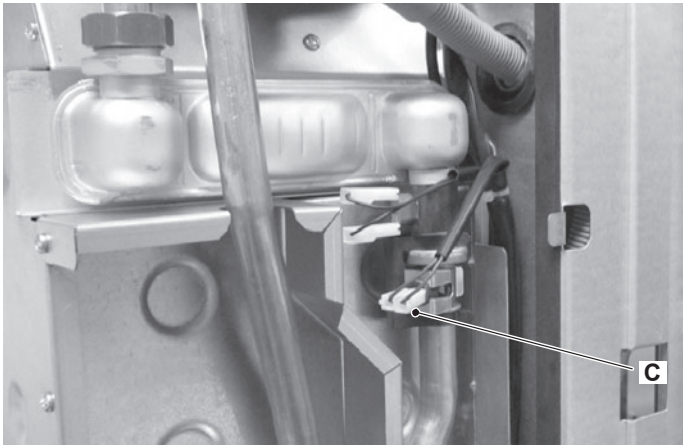

Figure 10.7

- 6 Keep pressed the reset button D for about 10 seconds until the lock-out signal lamp E blinks.
- 7 Connect the electrical connectors C of the c.h. temperature probe NTC in Figure 10.7.
- 8 The lamps F should give the indication as in Figure 10.8 (useful output, first step). If not, press the reset button repeatedly to obtain it.

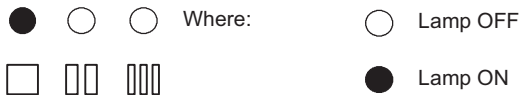

Figure 10.8

At this step it is possible to visualize the current setting by keeping the reset button D pressed for more than 5 seconds. The lamps F will flash a number of times corresponding to the setting Figure 10.9 (once for Riva Plus HE 24C ERP and four times for Riva Plus HE 28C ERP).

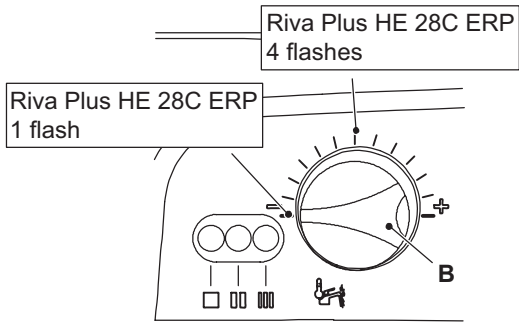

Figure 10.9

- 9 To change the setting turn the knob B on a position corresponding to the boiler models (Figure 10.9). By turning the knob B, the lock-out signal lamp E blinks quickly (2 per seconds) indicating that the setting has changed and must be memorised.
- 10 To memorize the setting keep pressed the reset button D for about 5 seconds until the lights F briefly blinks simultaneously.
- 11 Press the reset button D once until the lamps F give the indication as in Figure 10.10 (useful output, second step).

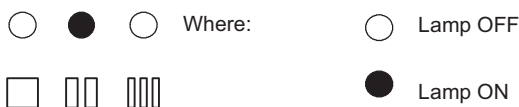

Figure 10.10

At this step it is possible to visualize the current setting by keeping the reset button D pressed for more than 5 seconds. The lamps F will flash a number of times corresponding to the setting Figure 10.11 (seven times for Riva Plus HE 24C ERP and Riva Plus HE 28C ERP).

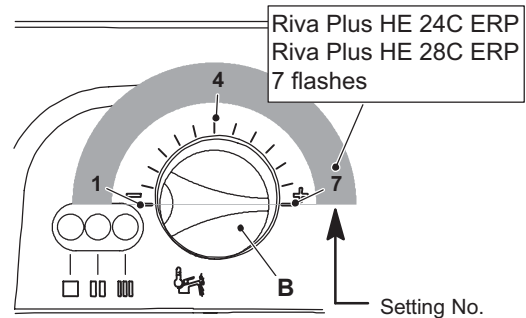

Figure 10.11

- 12 To change the setting turn the knob B on a position corresponding to the boiler model (Figure 10.11). By turning the knob B, the lock-out signal lamp E blinks quickly (2 per seconds) indicating that the setting has changed and must be memorised.
- 13 To memorize the setting keep pressed the reset button D for about 5 seconds until the lights F briefly blinks simultaneously.
- 14 To reset the boiler to the normal operation turn it OFF and ON by the function selector knob A.

10.7 Reignition frequency setting

It is possible to select the minimum time that must pass between two ignitions of the burner in c.h. function mode.

- 1 Turn the boiler ON positioning the function selector knob A as indicated in Figure 10.12.

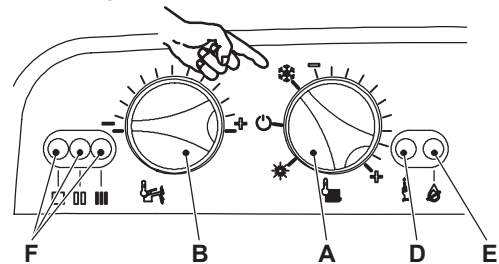

Figure 10.12

- 2 Keep pressed the reset button D for about 10 seconds until the lock-out signal lamp E blinks.
- 3 The lamps F should give the indication as in Figure 10.13 (reignition frequency). If not, press the reset button repeatedly to obtain it.

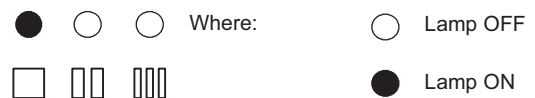

Figure 10.13

At this step it is possible to visualize the current setting by keeping the reset button D pressed for more than 5 seconds. The lamps F will flash a number of times corresponding to the setting (Figure 10.14).

- 4 To change the setting turn the knob B on a position corre-

ELECTRONIC CONTROL/IGNITION P.C.B.

sponding to the desired delay.

By turning the knob B, the lock-out signal lamp E blinks quickly (2 per seconds) indicating that the setting has changed and must be memorised.

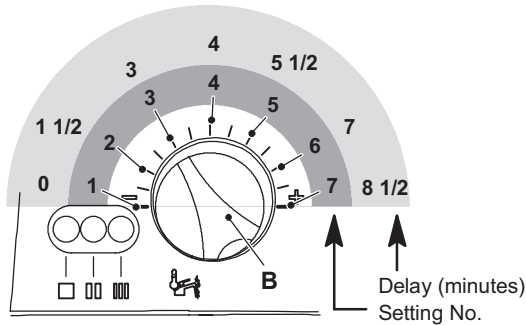

Figure 10.14

- 5 To memorize the setting keep pressed the reset button D for about 5 seconds until the lights F briefly blinks simultaneously.
- 6 To reset the boiler to the normal operation turn it OFF and ON by the function selector knob A. In any case, the boiler automatically resets to its normal operation after 10 minutes.

Factory setting = 3 minutes

10.8 Ignition gas pressure adjustment

- 1 Turn the boiler OFF.
 - 2 Remove the front panel of the case.
 - 3 Open the gas valve outlet pressure test point (7, see section 11.2) and connect the gauge.
 - 4 Turn the boiler ON positioning the function selector knob A as indicated in Figure 10.15 and ensure that the timer selector switch and room thermostat, if fitted, are set to "heat demand".
- Run the boiler in c.h. mode (do not open any d.h.w. tap).

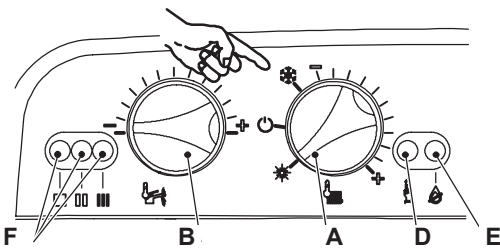

Figure 10.15

- 5 Keep pressed the reset button D for about 10 seconds until the lock-out signal lamp E blinks.
- 6 The lamps F should give the indication as in Figure 10.16. If not, press the reset button repeatedly to obtain it.

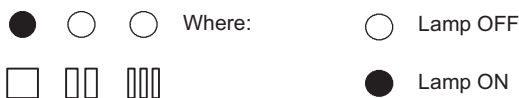

Figure 10.16

- 7 Keep pressed the reset button D for about 5 seconds until the lock-out signal lamp E is switched OFF.
- The boiler runs in c.h. mode and the lamps F give the indication as in Figure 10.17.

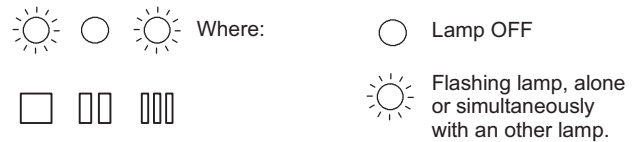

Figure 10.17

- 8 Rotate the knob B on a position corresponding to an adequate ignition pressure. Refer to the value indicated in the tables of the User/Installation manual (Technical information section, Gas pressures at the burner table).
By rotating clockwise the pressure increases.
- 9 Make a note of the position of the knob B.
- 10 Turn the boiler OFF and ON positioning the function selector knob A as indicated in Figure 10.18

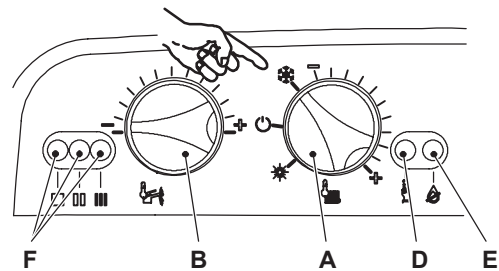

Figure 10.18

- 11 Keep pressed the reset button D for about 10 seconds until the lock-out signal lamp E blinks.
- 12 Press the reset button D repeatedly (4 times) until the lamps F give the indication as in Figure 10.19 (ignition pressure adjustment mode).

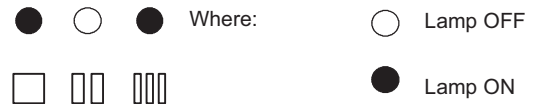

Figure 10.19

- 13 Turn the knob B to the minimum (fully counterclockwise) and then on the position corresponding to the position obtained on step 8.
By turning the knob B, the lock-out signal lamp E blinks quickly (2 per second) indicating that the setting has changed and must be memorised.
- 14 To memorize the setting keep pressed the reset button D for about 5 seconds until the lights F briefly blinks simultaneously.
- 15 To reset the boiler to the normal operation turn it OFF and ON by the function selector knob A checking the ignition pressure and that the burner lights up uniformly. In any case, the boiler automatically resets to its normal operation after 10 minutes.

10.9 Setting the d.h.w. flowmeter operation mode

When replacing the Electronic control/ignition p.c.b., it must be set for the correct operation of the d.h.w. flowmeter.

Note: the Electronic control/ignition p.c.b. spare part is factory set on mode 1.

For all the models covered by this manual:

- 1 Turn the boiler ON positioning the function selector knob A as indicated in Figure 10.20.
- 2 Turn knob B as indicated in Figure 10.20.

ELECTRONIC CONTROL/IGNITION P.C.B.

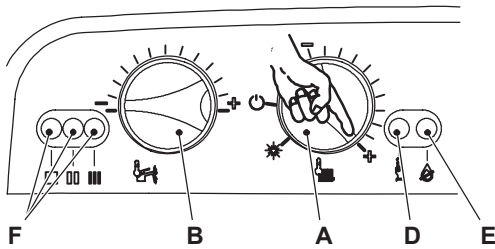

Figure 10.20

- 3 Keep pressed the reset button D for about 10 seconds until the lock-out signal lamp E blinks.
- 4 Press the reset button D repeatedly (4 times) until the lamps F give the indication as in Figure 10.21 (setting the d.h.w. flowmeter mode operation).

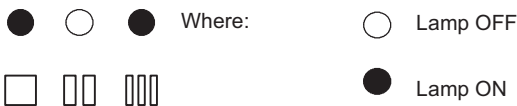

Figure 10.21

At this step it is possible to visualize the current setting by keeping the reset button D pressed for more than 5 seconds. The lamps F will flash a number of times corresponding to the setting (Figure 10.22).

- 5 Change the setting by turning the knob B on the position corresponding to the desired setting (Figure 10.22).
By turning the knob B, the lock-out signal lamp E blinks quickly (2 per seconds) indicating that the setting has changed and must be memorised.
- 6 To memorize the setting keep pressed the reset button D for about 5 seconds until the lights F briefly blinks simultaneously.

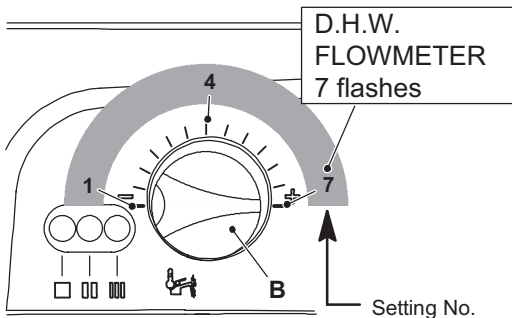

Figure 10.22

At this step it is possible to visualize the current setting by keeping the reset button D pressed for more than 5 seconds. The lamps F will flash a number of times corresponding to the setting of Figure 10.22 that must be seven times.

- 7 To reset the boiler to the normal operation turn it OFF and ON by the function selector knob A checking the ignition pressure and that the burner lights up uniformly. In any case, the boiler automatically resets to its normal operation after 10 minutes.

10.10 Checks

- ✓ Check that the fuses are complete

If the Electronic control/ignition p.c.b. does not supply any device (pump, fan, etc.) check that the fuses 14 (Figure 10.2) are complete.

If a fuse has blown replace it with one that has the same charac-

teristics after having identified the reason for failure.

- ✓ Lock sequence

Start the boiler until the burner is ignited.

With the burner firing, interrupt the gas supply. The Electronic control/ignition p.c.b. must carry out three complete ignition cycles and then, after about 3 minutes, goes to lock-out state.

By turning the boiler on and off by means of the function switch the device must not unlock and the burner must not turn on.

- ✓ Fan functioning device

With the boiler operating and the burner on, open the positive pressure test point of the Fan pressure connection devise. After opening it the burner must turn off.

10.11 Removal of the electronic control p.c.b



Warning: isolate the boiler from the mains electricity supply before removing any covering or component.

When replacing the Electronic control/ignition p.c.b. it is advisable to go through the setting modes of the boiler.

- 1 Gain access to the parts located inside the control panel as explained in the section "Control panel" page 5 of this manual.
- 2 Remove all the wiring connected to the Electronic control/ignition p.c.b..
To disconnect the connectors x1, x6 and x7 (1, 2 and 3 in Figure 10.2) delicately flex the hook present on one side of each socket.
To disconnect the connectors x4 and x2 (4 and 5 in Figure 10.2) press delicately the hook present on one side of each connector.
- 3 Remove the spindles of the c.h. and d.h.w. temperature adjustment knobs by delicately pulling them with pliers in the direction shown by the arrows in Figure 10.23.

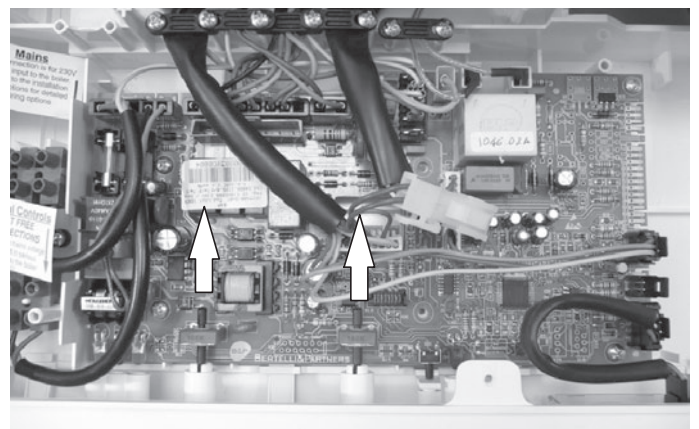

Figure 10.23

- 4 Unscrew the four screws that hold the Electronic control/ignition p.c.b. on to the control panel.
- 5 Remove it by lifting its rear edge and freeing it from any of the wiring.
- 6 Re-assemble the Electronic control/ignition p.c.b. following the removal procedures in the reverse order.

ELECTRONIC CONTROL/IGNITION P.C.B.

Important

When re-assembling the Electronic control/ignition p.c.b.:

- 7 Fit the p.c.b. into the control panel by first inserting the front lower edge under the control knob shafts. Lower the rear edge and ensure that no wiring is trapped beneath.
- 8 Insert the spindles in the control panel knobs until the notch A (Figure 10.24) reaches the potentiometer edge. It is not necessary to force them in the knob.
- 9 While tightening the screws that fix the Electronic control/ignition p.c.b. on the control panel, keep the p.c.b. towards the control panel fascia making sure of the contact between the boiler reset button B and the tab C (Figure 10.24).

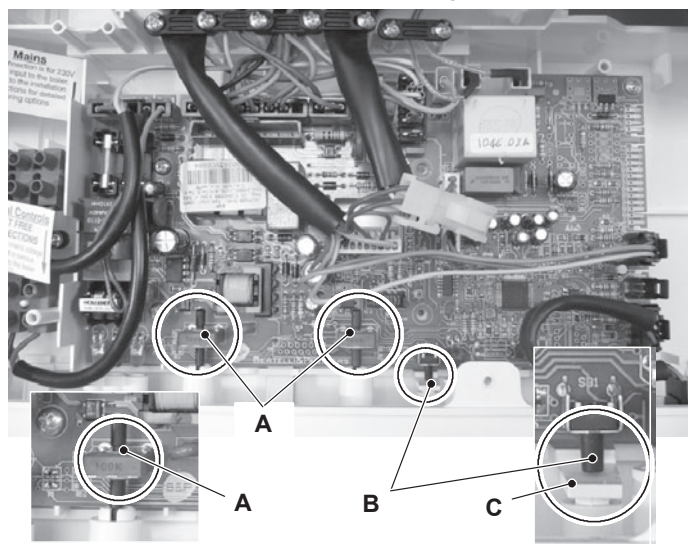

Figure 10.24

Attention

After installing the Electronic control/ignition p.c.b. :

- 10 Make sure the c.h. (🔧) and d.h.w. (🔧) temperature adjustment knobs can move freely for the complete range.
If not, remove the spindle again as described at step 3, turn the knob half a turn and re-insert the spindle.
- 11 Operate the boiler and close the gas inlet cock so that the boiler goes into the safety lock-out state.
Verify the correct operation of the boiler reset button by pressing and releasing it.



Warning: After cleaning or replacement as detailed above, if it deemed necessary to undertake a combustion analysis, refer to the appropriate chapter Maintenance of the installation instructions manual.

10.12 Thermal control in the ❄️ mode

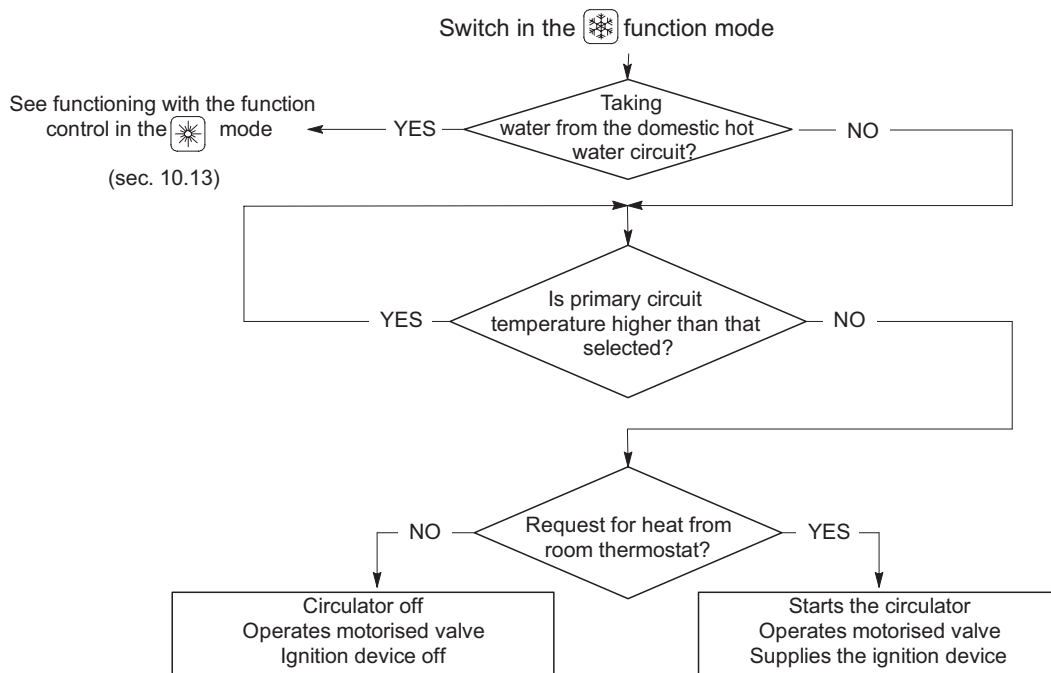

Figure 10.25

10.13 Thermal control in the ☀️ mode

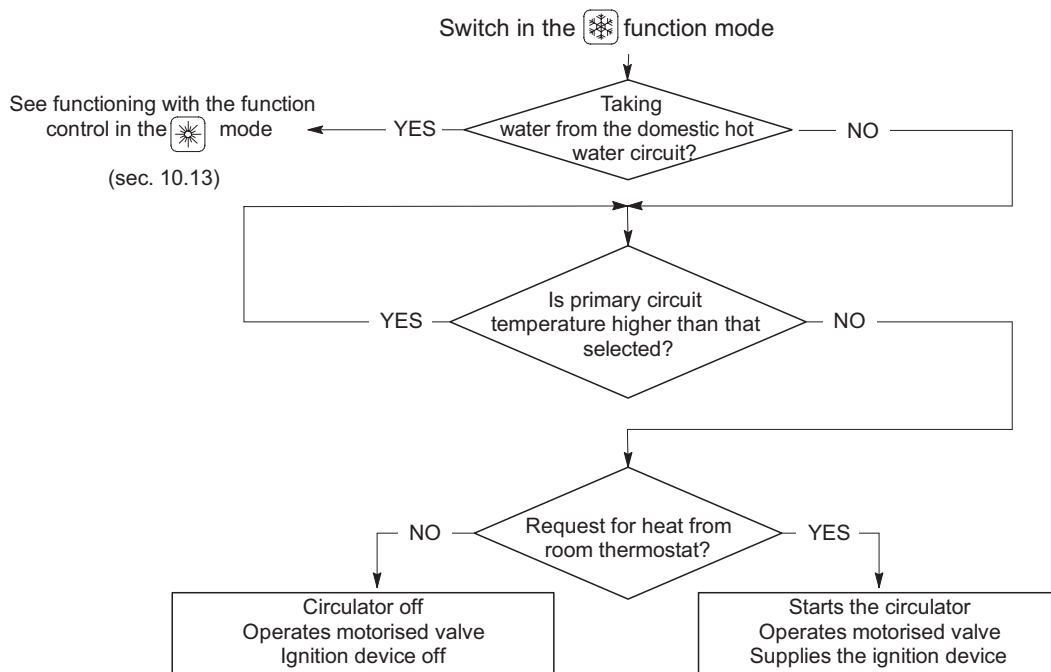

Figure 10.26

10.14 Ignition and control sequence

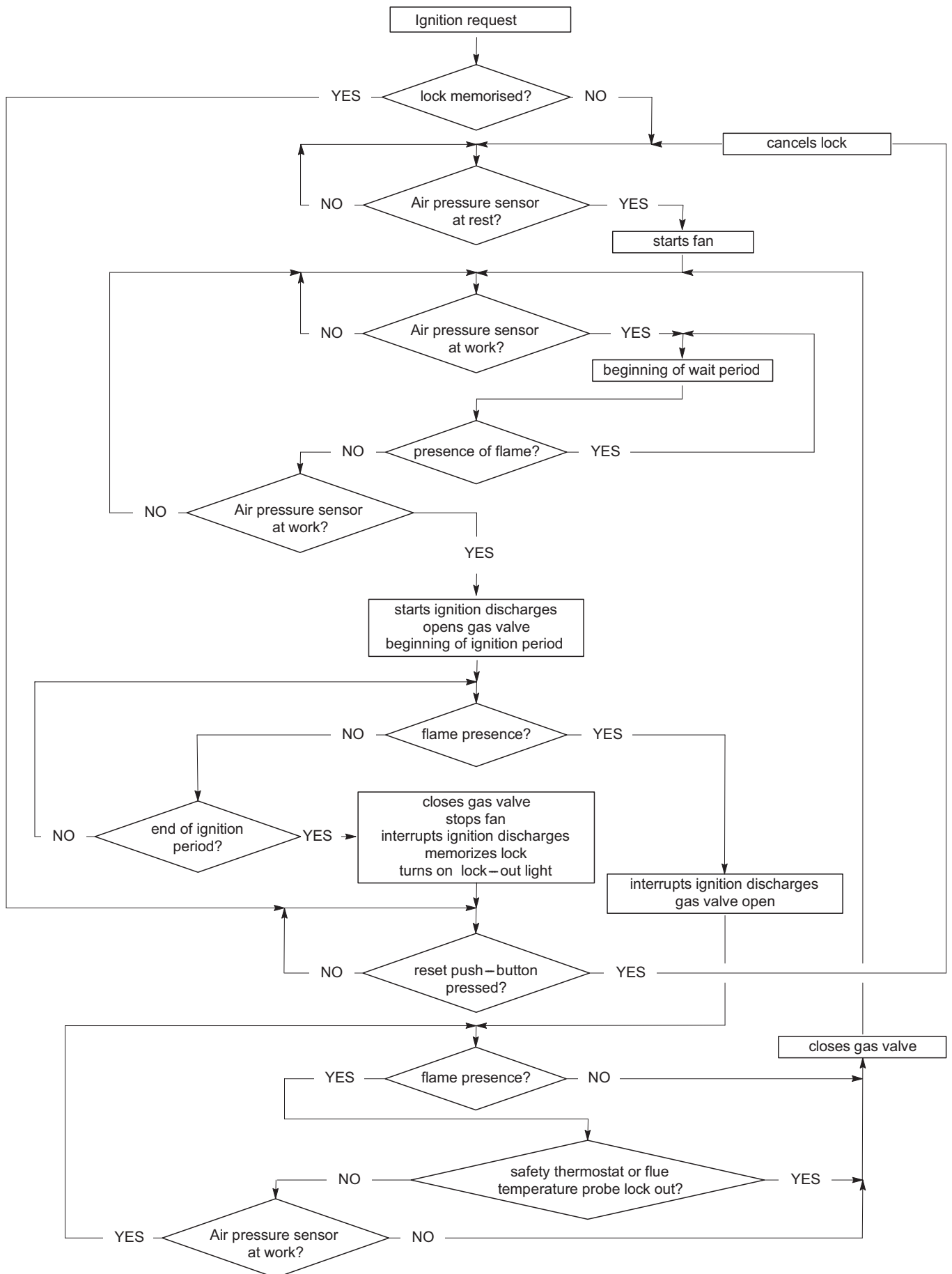

Figure 10.27

MODULATING GAS VALVE

11 MODULATING GAS VALVE

11.1 Function

The Modulating gas valve A in Figure 11.1 controls the gas inflow to the boiler burner.

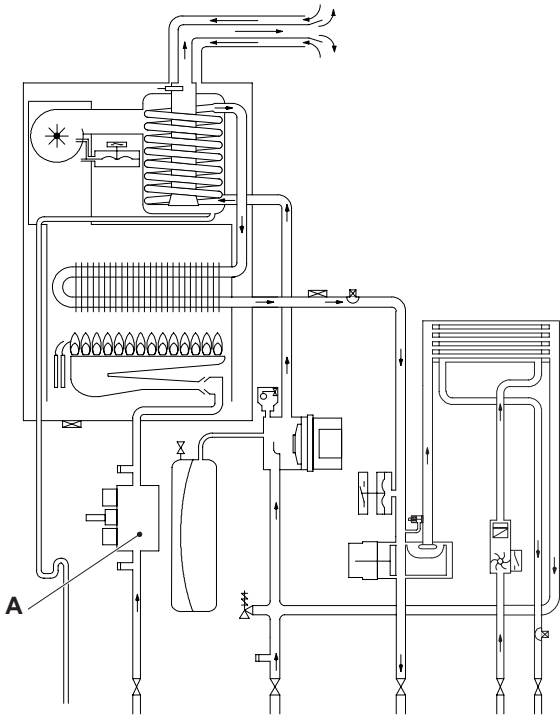

Figure 11.1

By means of an electric command given to the on-off operators the passage of the gas through the Modulating gas valve can be opened or closed.

By means of an electric command given to the modulation operator the pressure can be varied and therefore the gas flow rate to the burner (modulation). The modulation operator has mechanical components which allow the adjustment of the minimum and maximum pressure exiting the valve.

11.2 Nomenclature of the parts - (Figure 11.2)

- 1 Minimum gas pressure adjustment
- 2 Maximum gas pressure adjustment
- 3 Modulation operator's electric connectors
- 4 On-off operators electric connector
- 5 On-off operators
- 6 Gas valve inlet pressure test point
- 7 Gas valve outlet pressure test point
- 8 Modulation operator

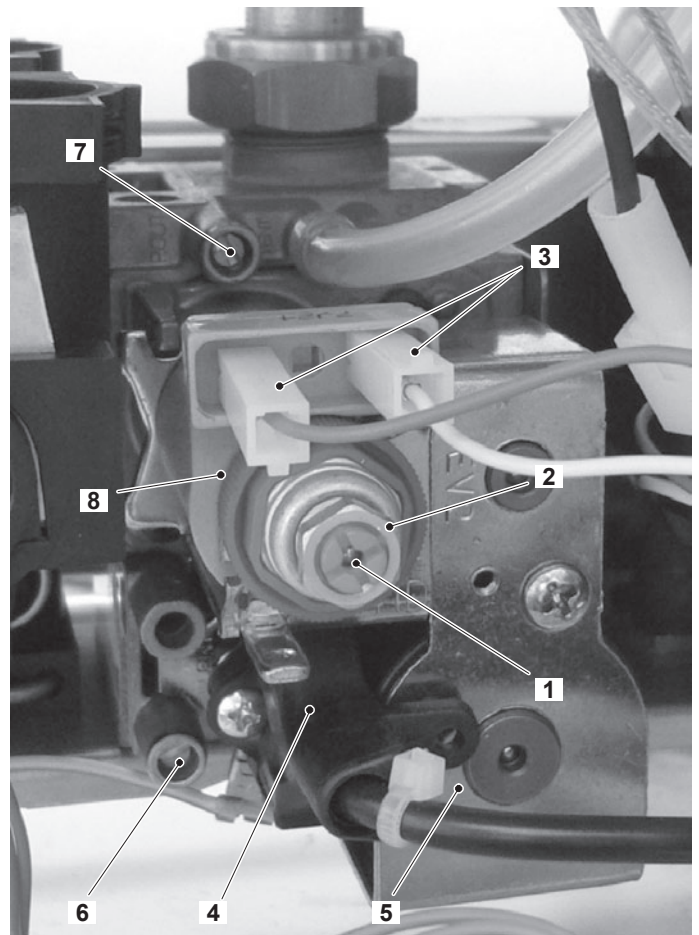

Figure 11.2

11.3 Adjustment

For the pressure values refer to the Technical data section of the User manual and Installation instructions.



Warning: isolate the boiler from the mains electricity supply before removing any covering or component.

- 1 Remove the case panels and the sealed chamber lid (section "Body panels" page 5).
- 2 Open the gas valve inlet pressure test point (6 in Figure 11.2) at the valve input, connect a suitable pressure gauge and check the gas pressure of the supply network.
- 3 Remove the gauge and close the pressure test point 6.
- 4 Open the gas valve outlet pressure test point (7 in Figure 11.2) and connect the gauge;

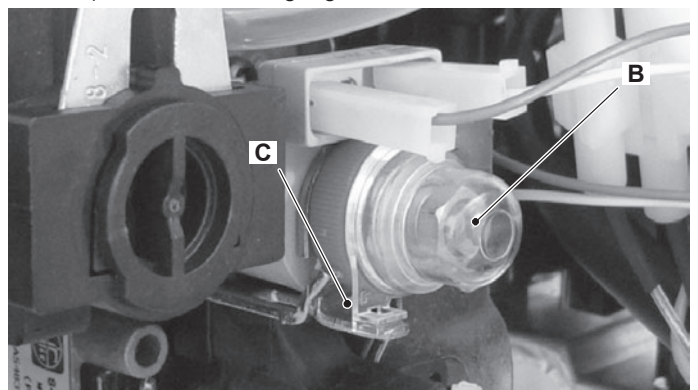

Figure 11.3

MODULATING GAS VALVE

- 5 Remove the protection cap B (Figure 11.3) from the mechanical pressure adjustment components levering with a flat screwdriver in the slots C.
- 6 Start the boiler at its maximum power.
Operate the boiler in d.h.w. mode or ensure that the boiler is not range rated if the test is carried out in c.h. mode.
- 7 Rotate the maximum gas pressure adjustment (2 in Figure 11.2) until you obtain the required pressure (by rotating clockwise the pressure increases).
- 8 Turn the boiler off and disconnect one of the two connectors (3 in Figure 11.2).
- 9 Start the boiler and rotate the minimum gas pressure adjustment (1 in Figure 11.2) until you obtain the required pressure (by rotating clockwise the pressure increases).
- 10 Turn the boiler off and re-connect the wire to the modulating operator.
- 11 Start the boiler and check again the maximum gas pressure setting.
- 12 Turn the boiler off and disconnect the gauge.

Important: after the gas pressure checks and any adjustment operations, all of the test points must be sealed and replace the adjustment protection cap.

11.4 Checks



Warning: isolate the boiler from the mains electricity supply before removing any covering or component.

- ✓ Check the modulation operator coil
 - 1 Remove the front panel of the case.
 - 2 Disconnect the connectors D (Figure 11.5) from the modulating operator and measure the electrical resistance of the coil. Its electrical resistance value must be approx. 80 Ω*.
- ✓ Check the on-off operators coils
 - 1 Remove the front panel of the case.
 - 2 Disconnect the electrical connector E (Figure 11.5).
 - 3 Measure the electrical resistance between the connector pins of the on-off operators as illustrated in Figure 11.4.

Upper on-off operator
approx. 6400 Ω*

Lower on-off operator
approx. 920 Ω*

*at ambient temperature.

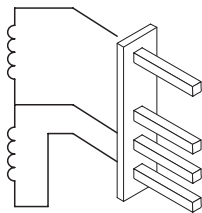

Figure 11.4

11.5 Removal of the on-off operators coils



Warning: isolate the boiler from the mains electricity supply before removing any covering or component.

- 1 Remove the front panel of the case.
- 2 Disconnect the connector E (Figure 11.5).
- 3 Unscrew the screw F and remove on-off operator coils.
- 4 Reassemble the coils carrying out the removal operations in reverse order.

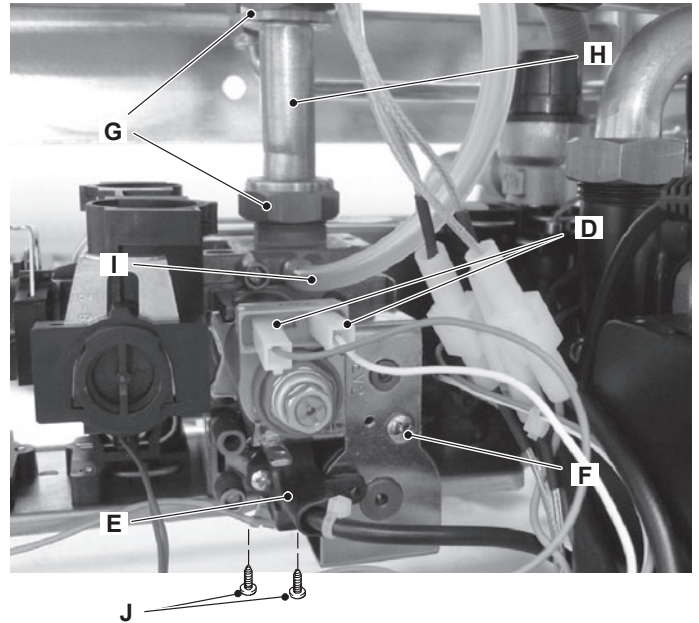

Figure 11.5

11.6 Removal of the gas valve



Warning: isolate the boiler from the mains electricity supply before removing any covering or component.

- 1 Remove the front panel of the case as explained in the section "Control panel" page 5 of this manual.
- 2 Disconnect the connectors D and E (Figure 11.5).
- 3 Turn off the gas supply and disconnect the gas isolation cock connector from the inlet port of the gas valve.
- 4 Unscrew the connectors G and remove the pipe H.
- 5 Remove the rubber pipe I.
- 6 Unscrew the screws J and remove the valve.
- 7 Reassemble the valve carrying out the removal operations in reverse order.

After any service operation on the components of the gas circuit check all the connections for gas leaks.



Warning: After cleaning or replacement as detailed above, if it deemed necessary to undertake a combustion analysis, refer to the appropriate chapter Maintenance of the installation instructions manual.

PRIMARY CIRCUIT PRESSURE SWITCH

12 PRIMARY CIRCUIT PRESSURE SWITCH

12.1 Function

The Primary circuit pressure switch (A in Figure 12.1) function is to check the presence of water in the primary hydraulic circuit and that the pressure is above the minimum.

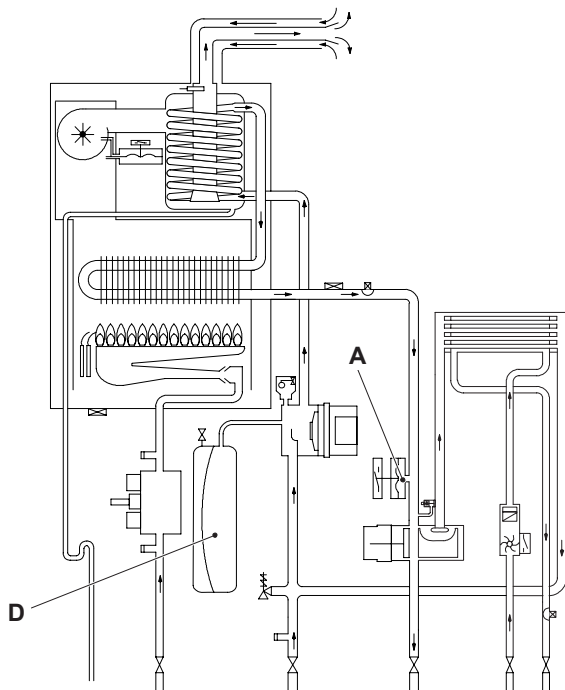

Figure 12.1

This device is connected to the electronic control p.c.b. and if, it does not activate the control board will indicate that a fault condition (see section "Operation lights" page 21) has occurred.

12.2 Checks



Warning: isolate the boiler from the mains electricity supply before removing any covering or component.

✓ Electrical check

It is possible to verify the general operation of the switch by measuring the electric resistance between the contacts C and N.O. of the switch.

- 1 Measure the electrical resistance between the tabs marked C and N.O. (Figure 12.2).
The contact must close (resistance zero) with c.h. pressure of 0,35 bar or higher.

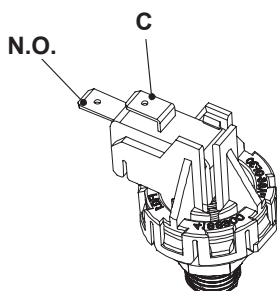

Figure 12.2

12.3 Removal



Warning: isolate the boiler from the mains electricity supply before removing any covering or component.

- 1 Remove the front and right hand side panels of the case, turn off the flow and return isolation valves and empty the primary circuit.
- 2 Remove the fixing spring B (Figure 12.3) and remove the primary circuit pressure switch A.
- 3 Disconnect the connectors.



Figure 12.3

- 4 Reassemble the primary circuit pressure switch in reverse order of removal.



Warning: to lubricate the O-ring gaskets exclusively use a silicone base grease compatible to be in contact with foods and approved by the local water Authorities.

EXPANSION VESSEL AND TEMPERATURE-PRESSURE GAUGE

13 EXPANSION VESSEL AND TEMPERATURE-PRESSURE GAUGE

13.1 Function

The Expansion vessel (D in Figure 12.1 function is to allow for the volume expansion of the c.h. circuit water due to the temperature rise.

13.2 Checks

- 1 Turn off the flow and return isolation valves and empty the primary circuit of the boiler.
- 2 Remove the protective cap E (Figure 13.1) from the valve on the top of the expansion vessel and connect a suitable air pressure gauge.

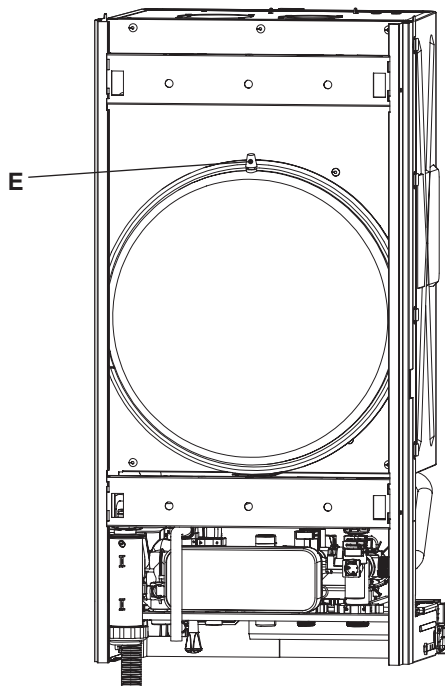

Figure 13.1 Rear view of the boiler

- 3 Check the pre-load pressure and refer to the section Expansion vessel in the User manual and installation instructions for the correct value.

13.3 Removal of the expansion vessel

If there is at least 400 mm clearance above the boiler and the rear exit flue can be easily removed, the expansion vessel can be changed without removing the boiler.



Warning: isolate the boiler from the mains electricity supply before removing any covering or component.

- 1 Remove the front and left hand side panels of the case, turn off the flow and return isolation valves and empty the primary circuit.
- 2 Completely unscrew the connection F, the locknut G (Figure 13.2) and remove the expansion vessel from the top of the boiler.

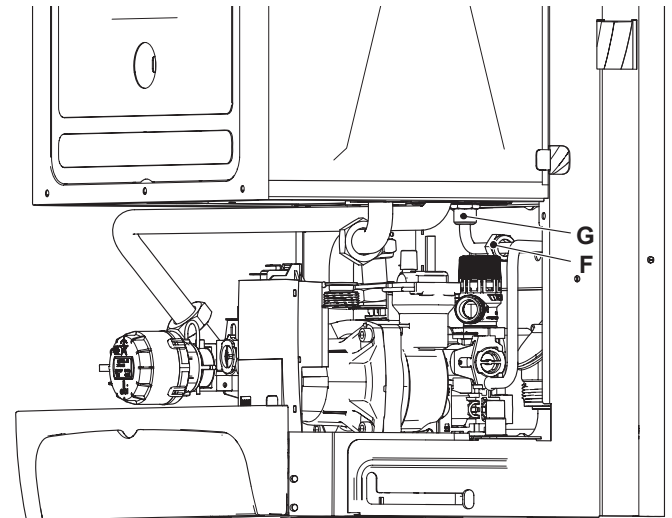

Figure 13.2

- 3 Re-assemble the parts in reverse order of removal.

13.4 Removal of the temperature-pressure gauge

- 1 Remove the front and right hand side panels of the case, turn off the flow and return isolation valves and empty the primary circuit.
- 2 Remove the fork H and the probe holder spring I (Figure 13.3).
- 3 Squeeze the tabs J to release the temperature-pressure gauge K and remove it.
- 4 Re-assemble the parts in reverse order of removal.

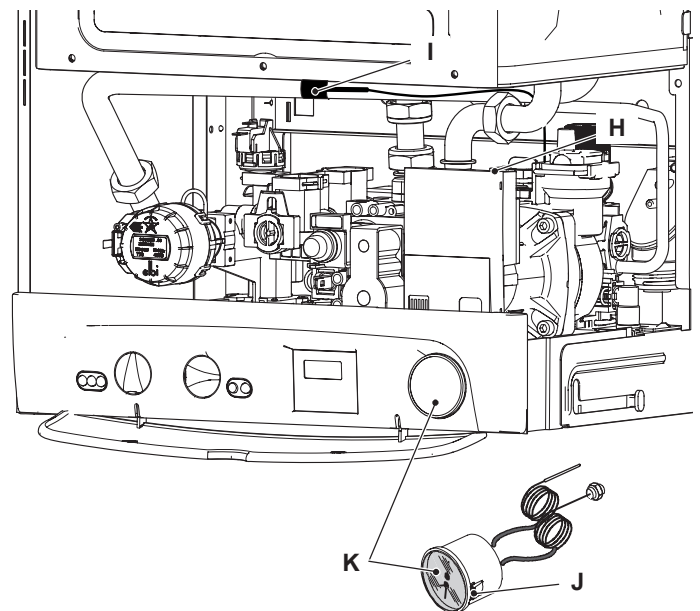

Figure 13.3

D.H.W. FLOW SWITCH, FILTER AND FLOW LIMITER

14 D.H.W. FLOWMETER, FILTER AND FLOW LIMITER

14.1 Function

The d.h.w. flowmeter A in Figure 14.1 is a device that generates an electrical signal when hot water is drawn.

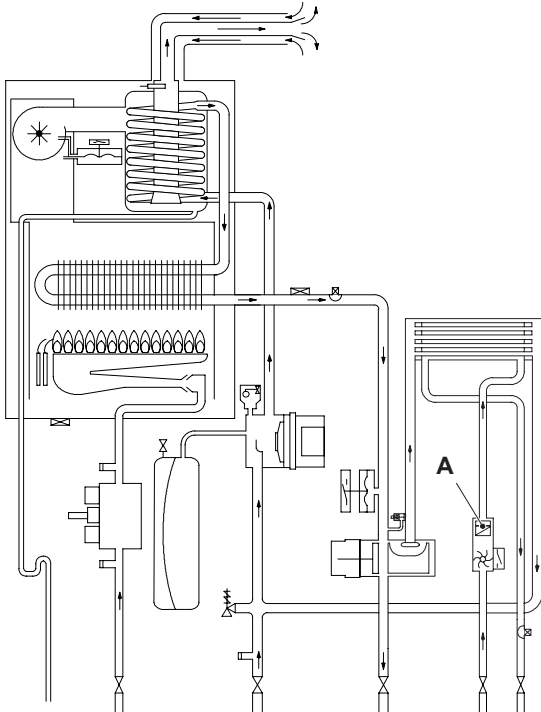

Figure 14.1

When the flow rate through the d.h.w. circuit reaches about 2,5 litres/min', the sensor closes the electric contact that switches the boiler d.h.w operation ON.

14.2 Description and location of parts - (Figure 14.2)

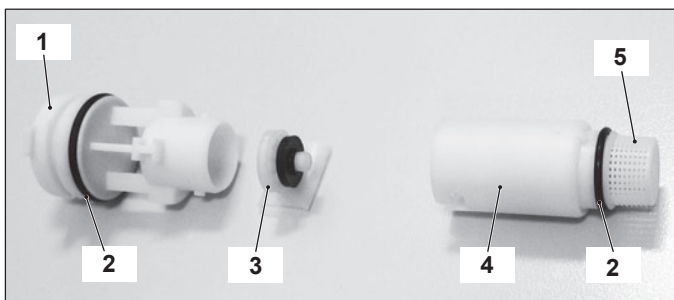

Figure 14.2

- 1 Flow switch plug
- 2 O-ring
- 3 Flow limiter (optional accessory)
- 4 Body with flow meter turbine
- 5 Filter

14.3 Removal of the sensor



Warning: isolate the boiler from the mains electricity supply before removing any covering or component.

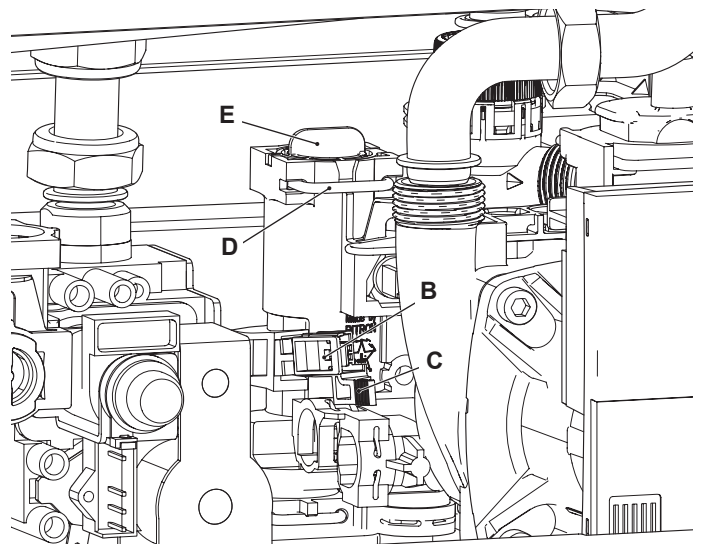

Figure 14.3

- 1 Remove the front panel of the case.
- 2 Disconnect the connectors B and remove the sensor holder C (Figure 14.3).
- 3 Remove the sensor.

14.4 Checks



Warning: isolate the boiler from the mains electricity supply before removing any covering or component.

✓ Sensor operation

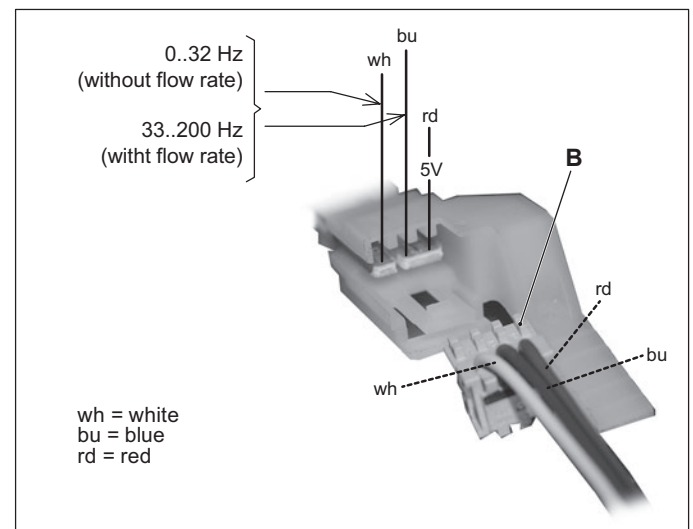

Figure 14.4

- 1 Remove the front panel of the case.
- 2 Don't disconnect the connectors B
- 3 Measure the electrical frequency at the leads of the sensor. Without flow rate the electrical frequency must be 0÷32Hz. With flow rate the electrical frequency must be 33÷200Hz.

14.5 Removal of the flow switch group and d.h.w. circuit filter



Warning: isolate the boiler from the mains electricity supply before removing any covering or component.

D.H.W. FLOW SWITCH, FILTER AND FLOW LIMITER

- 1 Remove the front panel of the case and empty the d.h.w. circuit.
- 2 Remove the fork D and pull up the flow switch plug E (Figure 14.3) with the help of a screwdriver.
- 3 To remove the body 4 with the filter from the flow switch group rotate the flow switch plug 1 (Figure 14.5).
- 4 Reassemble the parts following the removing sequence in reverse order.

14.6 Flow limiter

The Riva Plus HE 24C ERP model is factory fitted with a 10 litres/min. flow limiter (white).

To install the flow limiter:

- 1 Remove the flow switch group as explained in the section 14.5.
- 2 Rotate the flow switch plug 1 to separate it from the body 4 (Figure 14.5).

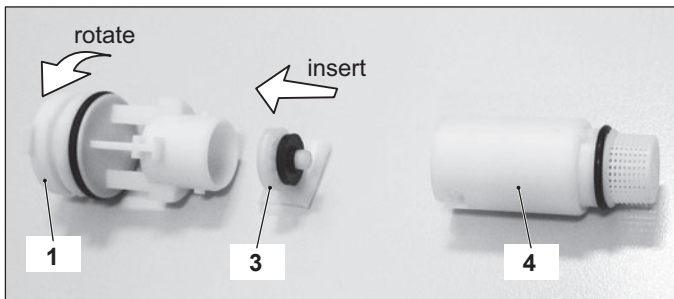

Figure 14.5

- 1 Insert the flow limiter 3 as shown in Figure 14.5.
- 2 Reassemble the group following the above sequence in reverse order.

TEMPERATURE PROBE

15 TEMPERATURE PROBE

15.1 Function

The Temperature probe has the function of converting the temperature of the water in the hydraulic circuit where it is installed into an electrical signal (resistance).

The relation between temperature and electrical resistance is stated in Figure 15.1.

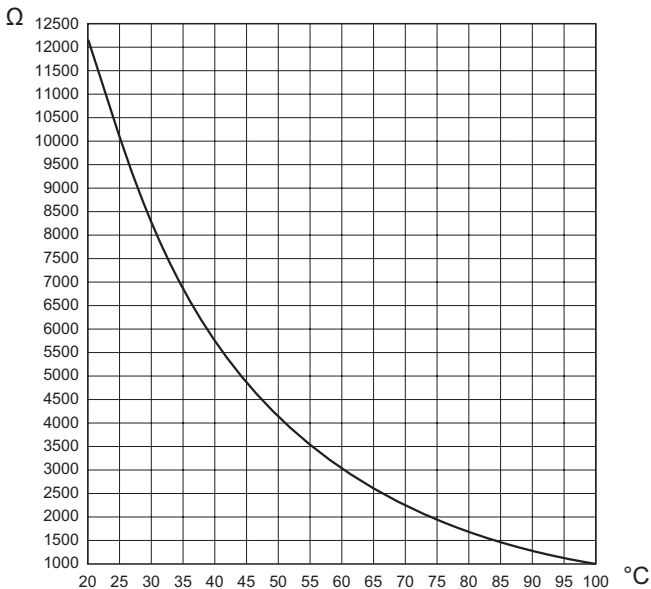

Figure 15.1

On the boiler there are two Temperature probes. One on the output of the primary heat exchanger (c.h. temperature probe) A in Figure 15.2 and Figure 15.3; one on the output of the d.h.w. heat exchanger (d.h.w. temperature probe) B in Figure 15.2 and Figure 15.4.

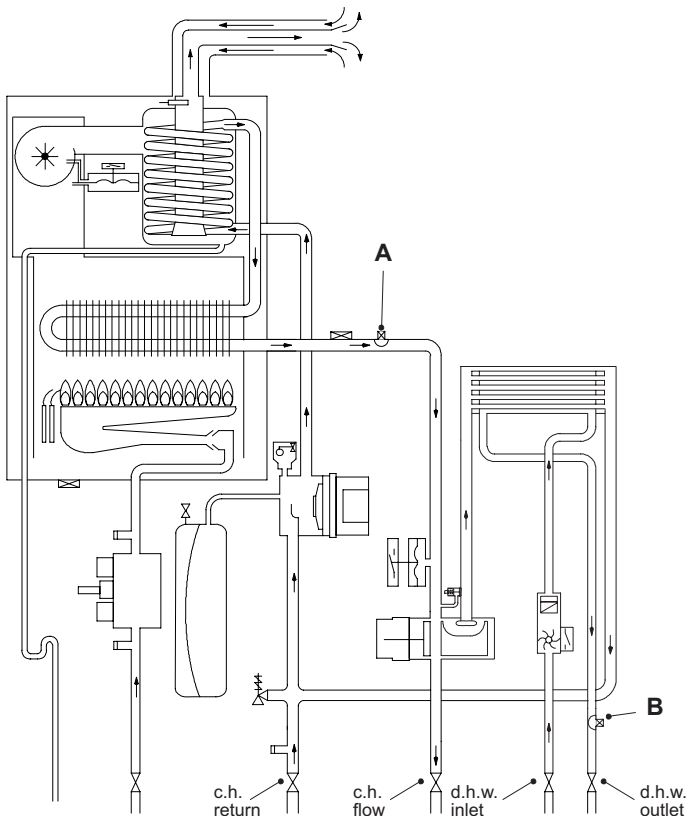

Figure 15.2

15.2 Checks

✓ Sensor operation



Warning: isolate the boiler from the mains electricity supply before removing any covering or component.

Disconnect the cable from the Temperature probe.

Measure the temperature of the pipe C where the Temperature probe is located and check the electrical resistance according to the graph in Figure 15.1.

15.3 Removal of the c.h. temperature probe



Warning: isolate the boiler from the mains electricity supply before removing any covering or component.

1 Remove all the case panels and the sealed chamber lid.

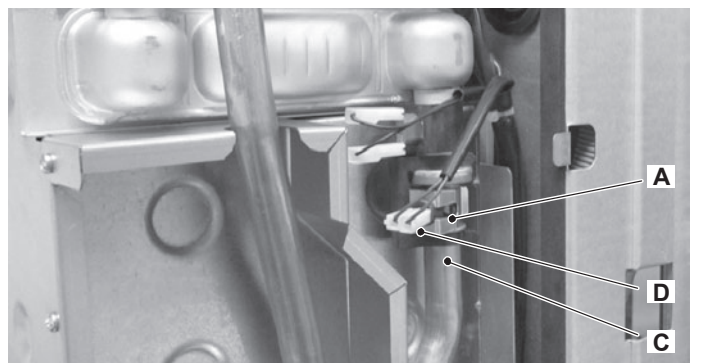

Figure 15.3

- 2 Remove the electric connector D and remove the c.h. Temperature probe A (Figure 15.3).
- 3 Reassemble the c.h. temperature probe carrying out the removal operations in reverse order.

15.4 Removal of the d.h.w. temperature probe



Warning: isolate the boiler from the mains electricity supply before removing any covering or component.

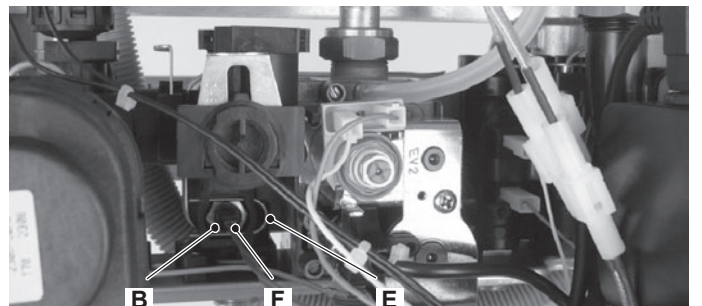

Figure 15.4

- 1 Remove the front panel of the case.
- 2 Empty the d.h.w. circuit of the boiler.
- 3 Remove the fixing spring E (Figure 15.4).
- 4 Remove the electric connector F and unscrew the d.h.w. Temperature probe B (Figure 15.4).
- 5 Reassemble the d.h.w. temperature probe carrying out the removal operations in reverse order.



Warning: to lubricate the O-ring gaskets exclusively use a silicone base grease compatible to be in contact with foods and approved by the local water Authorities.

BY-PASS VALVE

16 BY-PASS VALVE

16.1 Function

The By-pass valve A in Figure 16.1 is located between the c.h. water flow and return and its function is that of guaranteeing a minimum flow across the primary heat exchanger if the circulation across the c.h. system is completely closed.

The By-pass valve is inside of the diverter group.

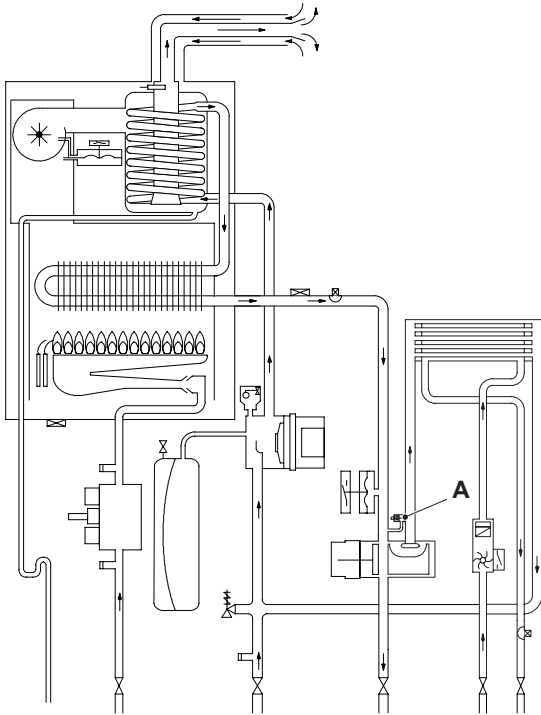

Figure 16.1

16.2 Removal



Warning: isolate the boiler from the mains electricity supply before removing any covering or component.

- 1 Remove all the case panels.
- 2 Empty the primary circuit of the boiler.
- 3 Remove the locking plate B and pull up the by-pass valve A (Figure 16.3).

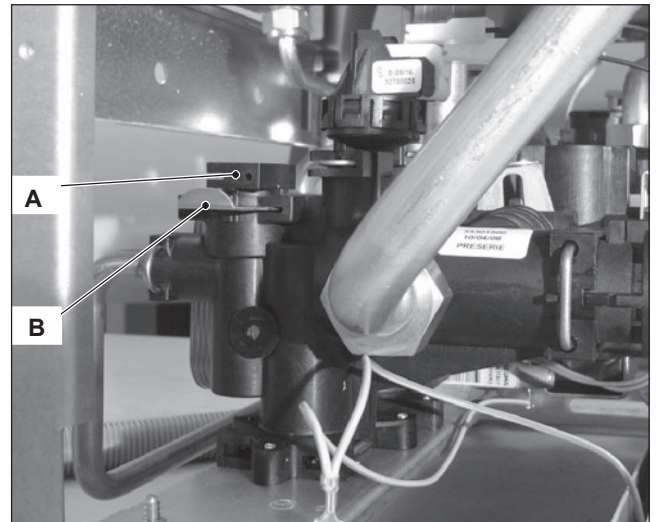

Figure 16.2

- 4 Reassemble the by-pass valve as illustrated in Figure 16.2 reversing the order of removal.



Warning: to lubricate the O-ring gaskets exclusively use a silicone base grease compatible to be in contact with foods and approved by the local water Authorities.



Attention: when reassembling the By-pass valve be sure that it is correctly oriented by matching the reference C with the notch D of the water group Figure 16.3.

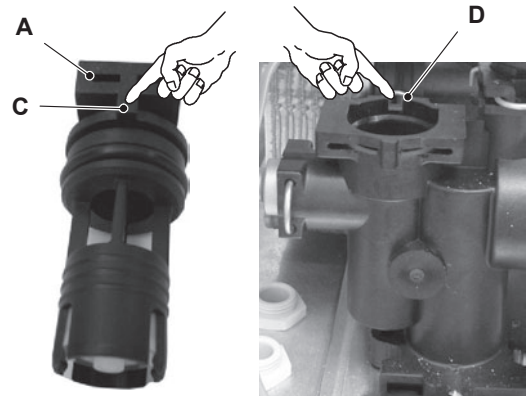

Figure 16.3

FAN AND AIR PRESSURE SENSOR

17 FAN AND AIR PRESSURE SENSOR

17.1 Function

The function of the Fan A (Figure 17.1 and Figure 17.2) is to force the products of combustion through the condensing heat exchanger to the outside air via the flue system.

The Fan is supplied by the full sequence ignition device at the beginning of the ignition cycle.

Its correct functioning is controlled by means of an Air pressure sensor B (Figure 17.1 and Figure 17.2).

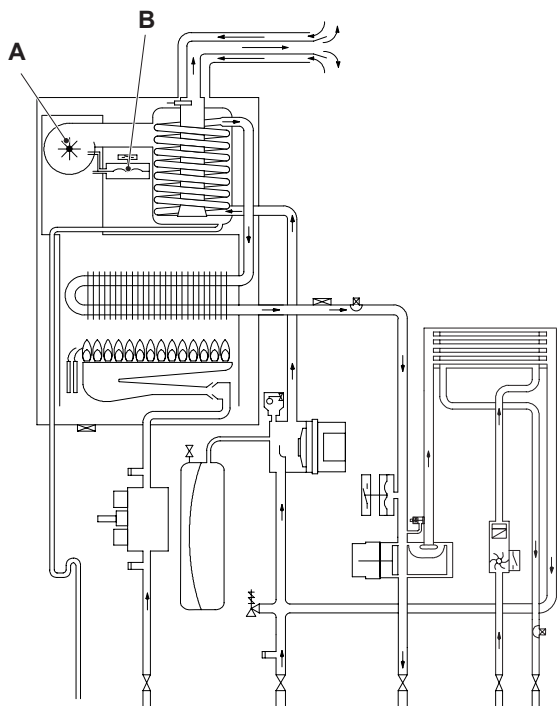

Figure 17.1

17.2 Checks

✓ Check of the fan



Warning: isolate the boiler from the mains electricity supply before removing any covering or component.

- 1 Remove all the case panels and the sealed chamber lid.
- 2 Disconnect the connectors C (Figure 17.2) and measure the electrical resistance of the motor that has to be about:
43 Ω - Riva Plus HE 24C ERP
25 Ω - Riva Plus HE 28C ERP
(at ambient temperature).

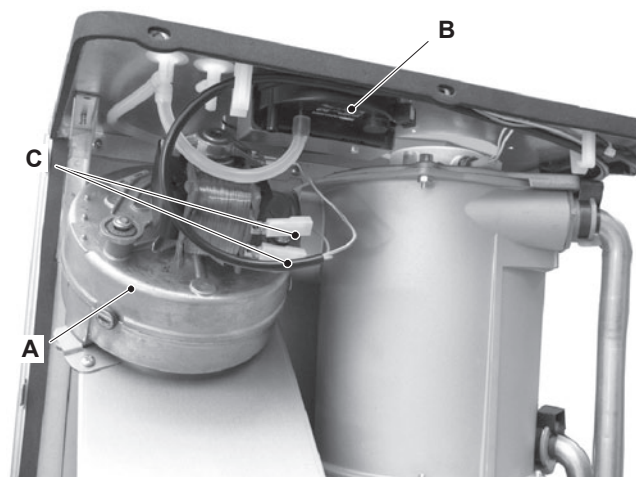

Figure 17.2

✓ Check of the Air pressure sensor operation

This test must be carried out with the sealed chamber closed.

- 1 Remove the caps of the pressure test points located on the top of the boiler and connect a differential pressure gauge (Figure 17.3).
- 2 Switch on the boiler.

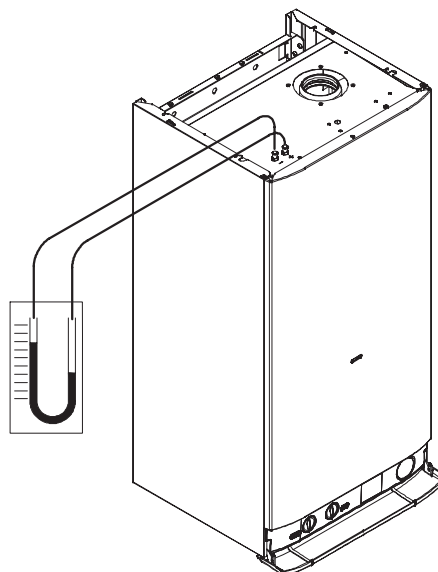



Figure 17.3

- 3 Run the boiler at minimum by disconnecting the gas valve modulation operator.
- 4 Compare the value on the gauge with the following:
18 Pa (0,18 mbar) - Riva Plus HE 24C ERP
25 Pa (0,25 mbar) - Riva Plus HE 28C ERP
- 5 Run the boiler at maximum (connect the modulation operator).
- 6 Compare the value on the gauge with the following:
75 Pa (0,75 mbar) - Riva Plus HE 24C ERP
115 Pa (1,15 mbar) - Riva Plus HE 28C ERP
- 7 With values less than (during Ignition):
36 Pa (0,36 mbar) - Riva Plus HE 24C ERP
65 Pa (0,65 mbar) - Riva Plus HE 28C ERP
The ignition is not allowed and appropriate fault indication is given (see section 10.4)

FAN AND AIR PRESSURE SENSOR

17.3 Removal of the Fan

 **Warning:** isolate the boiler from the mains electricity supply before removing any covering or component.

- 1 Remove all the case panels and the sealed chamber lid.
- 2 Disconnect the connectors C and the earth connection D (Figure 17.4).
- 3 Disconnect the pipe E by the pressure test point F (Figure 17.4).
- 4 Unscrew the screw G and remove the bracket H (Figure 17.4).

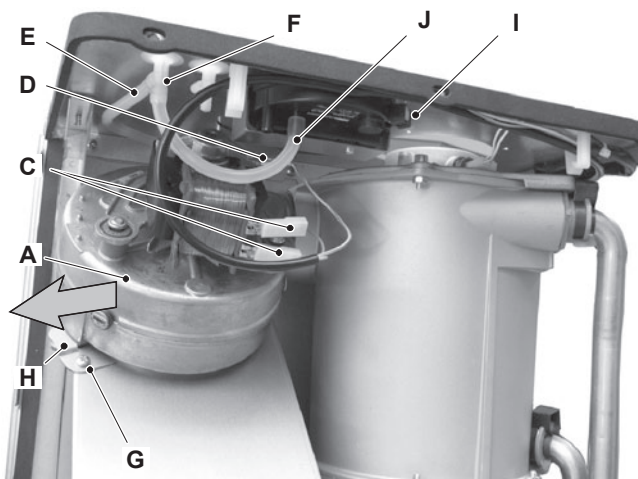





Figure 17.4

- 5 Remove the Fan by sliding it towards left (see the arrow in Figure 17.4).
- 6 Assemble the fan carrying out the removal operations in reverse sequence.

 **Warning:** Re-assembling the fan ensure that the hooks around the inlet port of the fan hung correctly on the flue hood.

 **Warning:** After cleaning or replacement as detailed above, if it deemed necessary to undertake a combustion analysis, refer to the appropriate chapter Maintenance of the installation instructions manual.

17.4 Removal of the Air pressure sensor

 **Warning:** isolate the boiler from the mains electricity supply before removing any covering or component.

- 1 Remove all the case panels and the sealed chamber lid.
- 2 Disconnect the wires I from the Air pressure sensor.
- 3 Remove the pipe J from the Air pressure sensor.
- 4 Unscrew the screws which hold the Air pressure sensor to the frame.
- 5 Assemble the Air pressure sensor carrying out the removal operations in reverse sequence.

 **Warning:** to correctly connect the Air pressure sensor, refer to Figure 17.5.

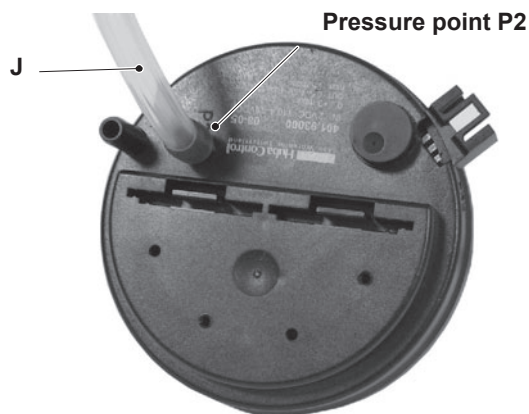



Figure 17.5

 **Warning:** After cleaning or replacement as detailed above, if it deemed necessary to undertake a combustion analysis, refer to the appropriate chapter Maintenance of the installation instructions manual.

IGNITION AND DETECTION ELECTRODES

18 IGNITION AND DETECTION ELECTRODES

18.1 Function

Three electrodes are fitted on the burner. Two of them are the ignition electrodes and are fitted near the front part of the burner. The ignition sparks take place between their metallic edges over the central ramp of the burner during the ignition sequence. The third electrode is the detection electrode and it detects the presence of the flame.

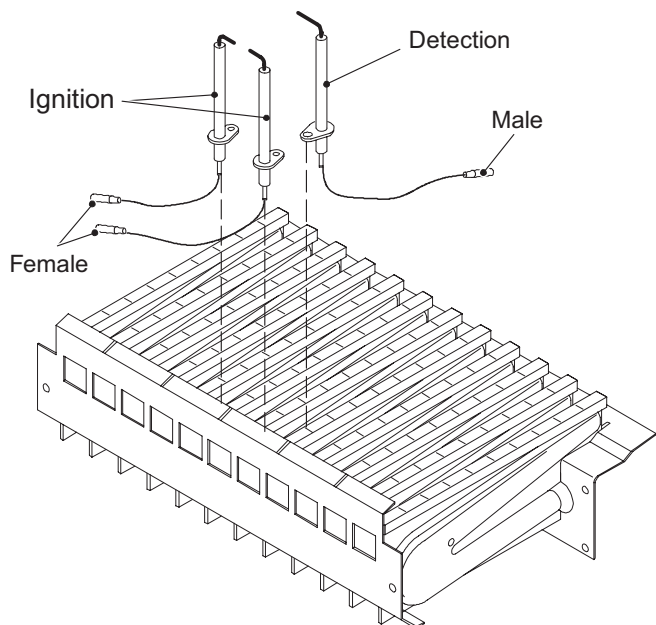

Figure 18.1

18.2 Checks

✓ Check the position of the electrode edges



Warning: isolate the boiler from the mains electricity supply before removing any covering or component.

- 1 Remove all the case panels, the sealed chamber lid and the combustion chamber lid.
- 2 Check for the correct distance between the metallic edges of the ignition electrodes (see Figure 18.2).

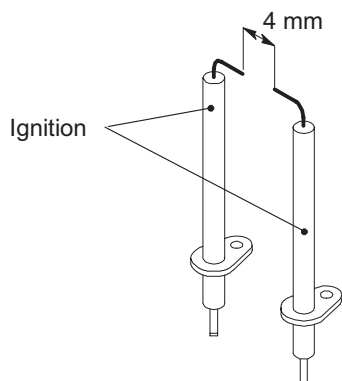

Figure 18.2

- 3 Check the integrity of the detection electrode and ensure that its metallic edge is correctly placed over the ramp of the burner.
- ✓ Check the connection wires.



Warning: isolate the boiler from the mains electricity supply before removing any covering or component.

- 1 Remove all the case panels, the sealed chamber lid and the combustion chamber lid.
- 2 Check for the integrity of the insulation of wires which connect the electrodes to the ignition device.

18.3 Removal



Warning: isolate the boiler from the mains electricity supply before removing any covering or component.

- 1 Remove all the case panels, the sealed chamber lid and the combustion chamber lid.
- 2 Disconnect the electrode wires from the full sequence ignition device.
- 3 Remove the plate E (see Figure 5.3 on page 12).
- 4 Remove the burner by unscrewing the four screws placed at the right and left sides of the burner.
- 5 Unscrew the screws A (Figure 18.3) which hold the electrodes to the burner.

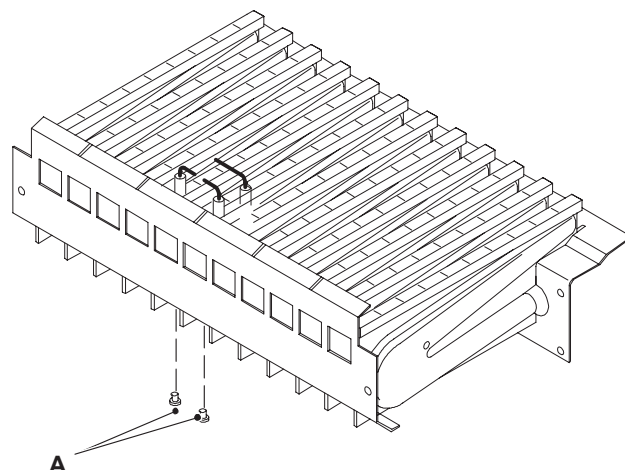

Figure 18.3

- 6 Extract the electrodes from the burner.
- 7 Assemble the electrodes carrying out the removal operation in reverse order. Refer to Figure 18.1 in order to recognise the electrodes and to correctly connect the wiring.

Note: the metallic edge of the detection electrode is longer than the one of the ignition electrodes.



Warning: After cleaning or replacement as detailed above, if it deemed necessary to undertake a combustion analysis, refer to the appropriate chapter Maintenance of the installation instructions manual.

SAFETY THERMOSTAT

19 SAFETY THERMOSTAT

19.1 Function

The safety thermostat A in Figure 19.1 and Figure 19.2 is a device that senses the temperature of the primary circuit water which flows in the outlet pipe of the primary heat exchanger. If the temperature control system of the boiler fails and the temperature of the primary circuit reaches a dangerous temperature, the safety thermostat opens the electric circuit that supplies the on-off operators of the gas valve. Consequently, the full sequence ignition device attempts to light the burner and, at the end, locks the boiler and lights the lock-out signal lamp.

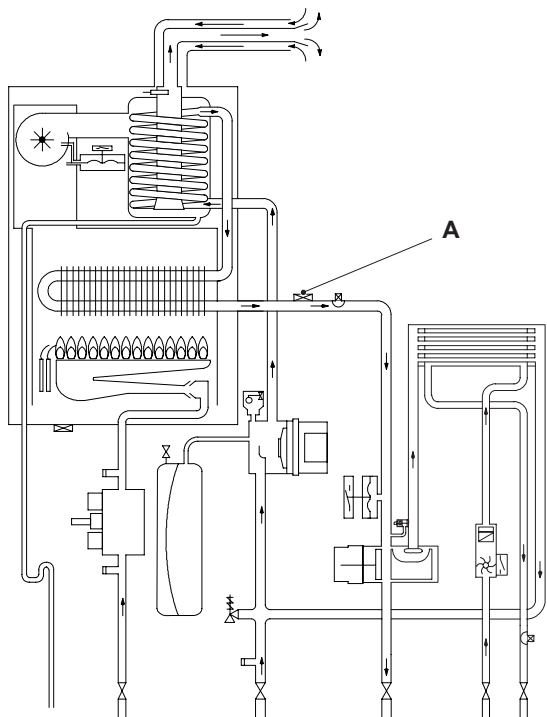

Figure 19.1

19.2 Checks

✓ Overheat temperature value

- 1 Set the temperature control knobs to their max. position and run the boiler in d.h.w. and c.h.
- 2 Allow the boiler to reach its maximum operating temperature (monitor the temperature gauge on the instrument panel). The boiler should maintain a temperature below that of the safety thermostat and no overheat intervention should occur.



Warning: isolate the boiler from the mains electricity supply before removing any covering or component.

✓ Electrical function

- 1 Remove all the case panels and the lid of the sealed chamber.
- 2 Disconnect the wiring B of the safety thermostat and check its electrical function. Normally (no intervention) the contact must be closed (electrical resistance zero Ω).

19.3 Removal



Warning: isolate the boiler from the mains electricity supply before removing any covering or component.

- 1 Remove all the case panels and the lid of the sealed chamber.

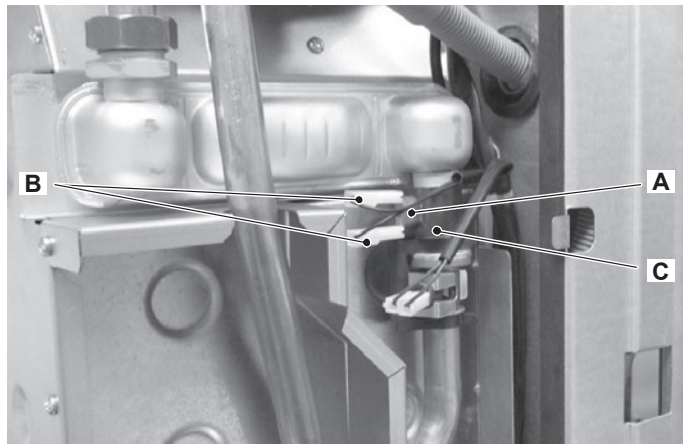

Figure 19.2

- 2 Disconnect the wiring B (Figure 19.2).
- 3 Remove the spring C which holds the overheat thermostat on the pipe of the primary heat exchanger and remove it.
- 4 Reassemble the overheat thermostat carrying out the operations in reverse order.
- 5 Apply an adequate quantity of heat conducting compound between the pipe and the thermostat.



Warning: After cleaning or replacement as detailed above, if it deemed necessary to undertake a combustion analysis, refer to the appropriate chapter Maintenance of the installation instructions manual.

FLUE TEMPERATURE PROBE NTC

20 FLUE TEMPERATURE PROBE NTC

20.1 Function

The Flue temperature probe NTC A in Figure 20.2 and Figure 20.3 senses the temperature of the combustion products that flow through the condensing heat exchanger.

The relation between temperature and electrical resistance is stated in Figure 20.1.

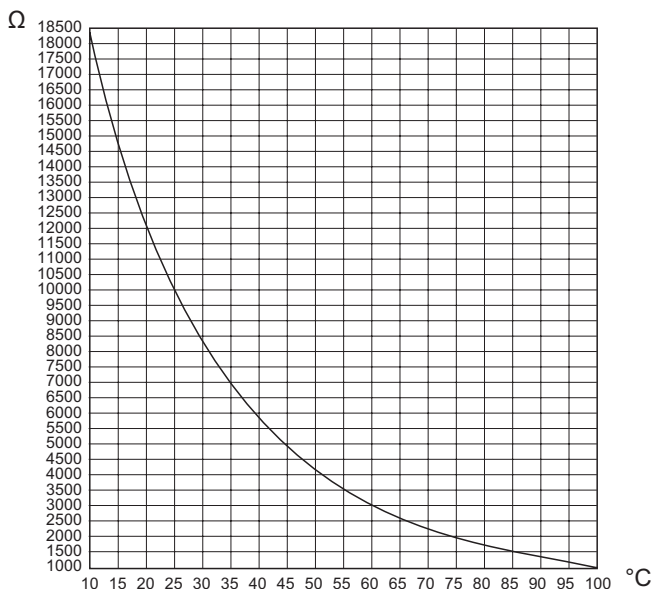

Figure 20.1

If the temperature of the combustion products circuit reaches the limit temperature, the Flue temperature probe NTC reduces the gas flow rate to the burner. The temperature of the combustion products should decrease to a safe value temperature.

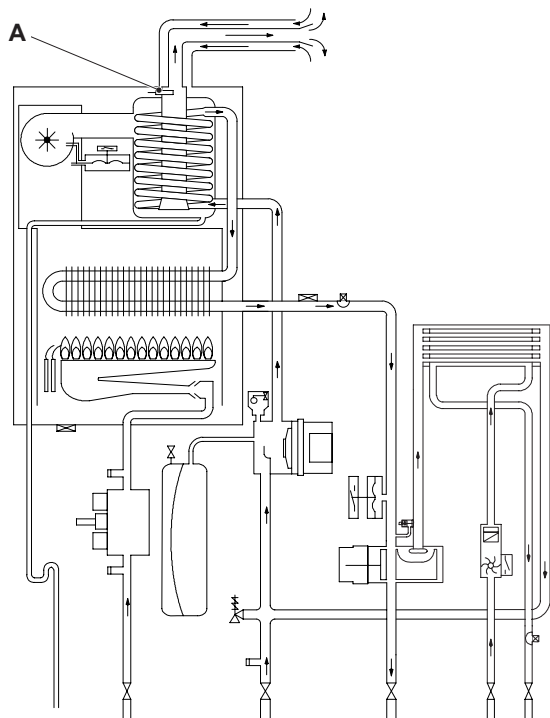

Figure 20.2

In the case that the temperature of the combustion products reaches a potentially dangerous value, it stops the boiler operation. It is therefore allowed the use of plastic materials for the flue outlet pipes and bends.

The use of kits different from the original isn't however allowed, since the flue pipes are integral parts of the boiler.

If not, the electronic control p.c.b. attempts to light the burner and, at the end, locks the boiler and lights the lock-out signal lamp.

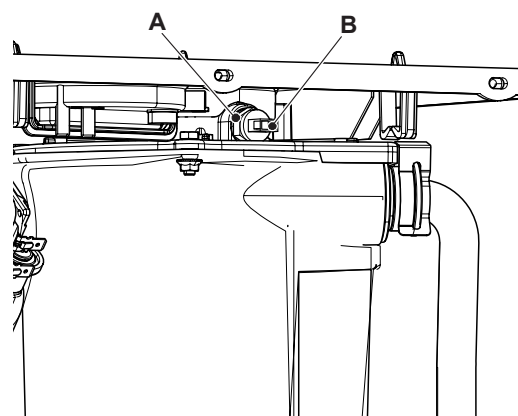

Figure 20.3

20.2 Checks

- ✓ Overheat temperature value
 - 1 Set the temperature control knobs to their max. position and run the boiler in d.h.w. and c.h.
 - 2 Allow the boiler to reach its maximum operating temperature (monitor the temperature gauge on the instrument panel). The boiler should maintain a temperature below that of the Flue temperature probe NTC and no overheat intervention should occur.
- ✓ Temperature-resistance relationship.
 - 1 Remove the probe (see section "Removal" page 40) to have it at room temperature.
 - 2 The electric resistance of the Flue temperature probe NTC at room temperature of 20°C must be of approximately 12000 Ω
 - 3 For other temperatures of the probe check the electrical resistance according to the graph (Figure 20.1).

20.3 Removal



Warning: isolate the boiler from the mains electricity supply before removing any covering or component.

- 1 Remove all the case panels and the sealed chamber lid.
- 2 Disconnect the wires B from the Flue temperature probe NTC (Figure 20.3).
- 3 Unscrew and remove the thermostat probe A (Figure 20.3) from the condensing heat exchanger.
- 4 Assemble the Flue temperature probe NTC carrying out the removal operations in reverse sequence.

CONDENSATE TRAP

21 CONDENSATE TRAP

21.1 Function

The condensate trap A in Figure 21.1 and Figure 21.2 allows the discharge of the condensate via the condensate drain pipe avoiding in the mean time the escape of combustion products. A plastic ball closes the trap outlet in case that the trap is empty.

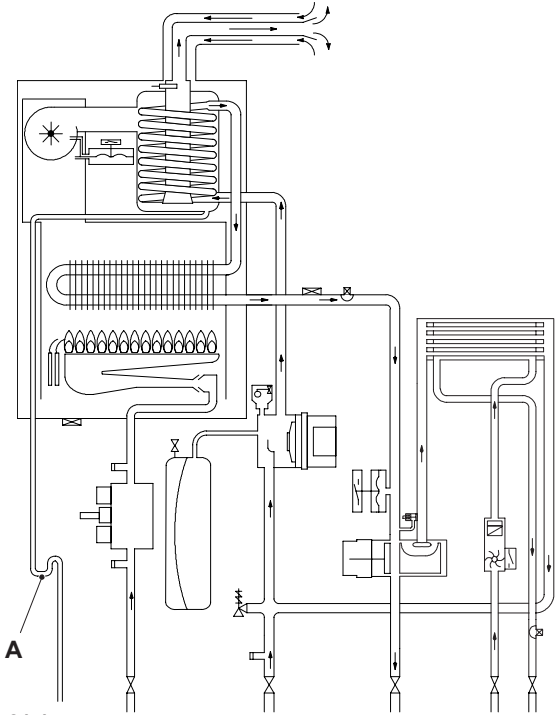

Figure 21.1

If the drain pipe is plugged or in any case in which the condensate isn't correctly evacuated, the condensate level rises filling the trap and reaching the condensing heat exchanger. When the condensate reaches the lower part of the exchanger obstructs the exhaust gas flow and the boiler stops (no signal from the air pressure sensor).

21.2 Removal



Warning: isolate the boiler from the mains electricity supply before removing any covering or component.

- 1 Remove the front and right case panels.
- 2 Disconnect the trap from the draining pipe.
- 3 Using pliers, remove the spring B moving it upwards.
- 4 Disconnect the rubber pipe C.
- 5 Unscrew the nut D and lower the trap.
- 6 Disconnect the wirings from the trap.
- 7 Reassemble carrying out the removal operations in reverse order.

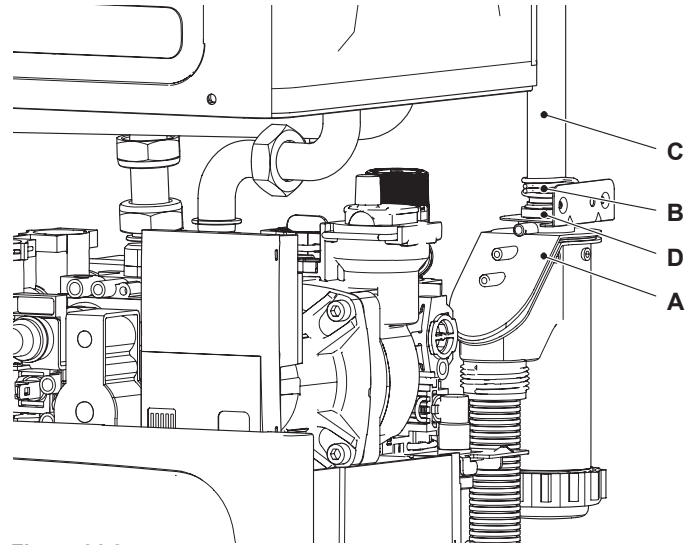

Figure 21.2

SHORT SPARE PARTS LIST

22 SHORT SPARE PARTS LIST

Key	G.C. part no.	Description	Q.ty	Manufacturer part no.	Manufacturer's reference
1	173 - 148	Burner (mod. Riva Plus HE 24C ERP)	1	KI1004 102	Polidoro
	173 - 149	Burner (mod. Riva Plus HE 28C ERP)	1	KI1004 147	
2	H74 - 599	Injectors for natural gas (mod. Riva Plus HE 24C ERP)	12	BI1213 109	Polidoro
		Injectors for natural gas (mod. Riva Plus HE 28C ERP)	14		
	169 - 070	Injectors for LPG (mod. Riva Plus HE 24C ERP)	12	KI1064 506	
		Injectors for LPG (mod. Riva Plus HE 28C ERP)	14		
3		Expansion vessel (mod. Riva Plus HE 24C ERP, Riva Plus HE 28C ERP)	1	BI1262 100	CIMM 8 litres
4	H20 - 984	Main heat exchanger (mod. Riva Plus HE 24C ERP)	1	BI1262 101	
	H20 - 985	Main heat exchanger (mod. Riva Plus HE 28C ERP)	1	BI1262 102	
5	H74 - 578	Fan (mod. Riva Plus HE 24C ERP)	1	BI1536 105	Fime
	H74 - 604	Fan (mod. Riva Plus HE 28C ERP)	1	BI1536 113	Fime
6	H03 - 746	Gas valve	1	BI1093 105	Sit 845
7	H74 - 576	Air pressure sensor	1	BI1536 103	HUBA 0-3 mbar
8	H50 - 189	Safety valve	1	BI1181 100	Watts
9	E83 - 178	Combustion chamber side panels	2	BI1326 100	
10	E83 - 180	Combustion chamber rear panel (mod. Riva Plus HE 24C ERP)	1	BI1326 107	
	E83 - 181	Combustion chamber rear panel (mod. Riva Plus HE 28C ERP)	1	BI1326 108	
11	H74 - 591	Combustion chamber front panel (mod. Riva Plus HE 24C ERP)	1	BI1536 110	
	H74 - 592	Combustion chamber front panel (mod. Riva Plus HE 28C ERP)	1	BI1536 111	
12		Electronic regulation p.c.b.	1	BI2015 105	Bertelli & Partners
13	E01 - 204	D.h.w. heat exchanger (Riva Plus HE 24C ERP)	1	BI1001 101	
	E01 - 205	D.h.w. heat exchanger (Riva Plus HE 28C ERP)	1	BI1001 102	
14		Pump	1	BI1672 100	
15	H74 - 545	Primary circuit pressure switch	1	BI1351 118	
16	169 - 010	D.h.w. flowmeter	1	BI1441 104	
17	H74 - 535	Three way diverter valve (electric actuator)	1	BI1431 100	
18	E83 - 101	Overheat thermostat	1	BI1172 105	ELTH - type 261
19	H74 - 589	Flue temperature probe NTC	1	BI1536 104	
20	H44 - 170	Fuse 3,15 AF	2	BI1295 108	
21	169 - 016	Temperature probe (d.h.w. circuit)	1	KI1042 501	
22	H74 - 553	Temperature probe (main circuit)	1	BI1442 106	
23	E83 - 127	Ignition electrode (left)	1	BI1123 101	
24	E83 - 126	Ignition electrode (right)	1	BI1123 103	
25	E83 - 122	Detection electrode	1	BI1123 102	
26	E83 - 145	Temperature-pressure gauge	1	BI1475 108	IMIT
27		Recuperator	1	BI1442 121	

SHORT SPARE PARTS LIST

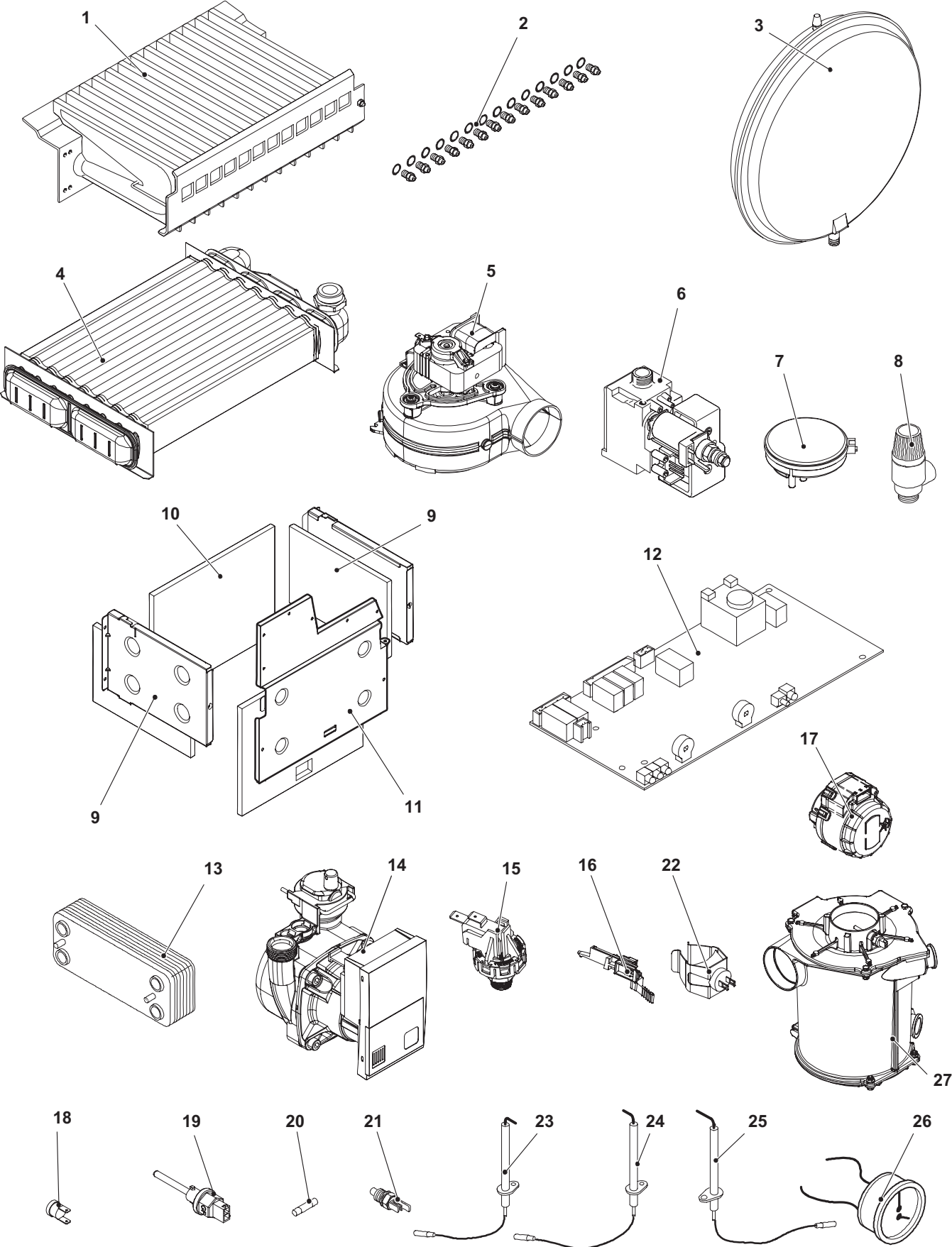

Figure 22.1



17962.2514.0 4315 44A4 UK



Biasi UK Ltd
Commercial Road
Leamore Enterprise Park
WALSALL

WS2 7NQ

Sales Tel. 01922 714600
Tech. Service Tel. 01922 714636
www.biasi.co.uk

