

INSTRUCTION MANUAL

INSTALLATION, OPERATION AND MAINTENANCE

Gas-fired condensing
central heating boilers

COMBI BOILERS

ECOCONDENS SILVER PLUS -20

ECOCONDENS SILVER PLUS -25

ECOCONDENS SILVER PLUS -35

SYSTEM BOILERS

ECOCONDENS SILVER PLUS -20

ECOCONDENS SILVER PLUS -25

ECOCONDENS SILVER PLUS -35



DEAR CUSTOMER

Congratulations on having chosen **termet** product.

We are glad that we can offer you modern, economical and environmentally friendly product, meeting particularly high requirements of European Standards.

Please read this instruction manual carefully as the knowledge of service rules and manufacturer's recommendations are the conditions of reliable, efficient and safe operation of the appliance.

Please keep this instruction manual for the whole operation life of the boiler.

We wish you satisfaction in using our product.

termet

IMPORTANT INFORMATION

- Read the instruction manual before you perform the installation and operation of the boiler.
- This instruction manual is an integral equipment of the boiler. It should be kept through the whole operation life of the boiler and carefully read. It contains all the information and warnings for safety during installation, use and maintenance to be followed.
- The boiler is complicated appliance as it contains numerous precise mechanisms.
- Reliable operation of the boiler depends mainly on appropriate performance of systems that boiler cooperates with such as:
 - gas system,
 - flue gas-air system,
 - central heating system,
 - domestic hot water system.
- Flue gas - air installation for C type boilers should be made of separately approved and introduced on the market gas - air system. Adapters connecting the boiler with a pipe system must have a measuring points. Flue gas – air system must meet the specifications set out in section 3.8 of this manual.
- Flue gas - air system must be tight. Leaks on the connections of flue gas pipes can result in flooding of the boiler by condensate. Manufacturer is not liable for damage and malfunction of the boiler arising out from above mentioned reason.
- **Installation of the boiler should be performed only by a qualified person¹⁾. Make sure that the installer has confirmed in writing the tightness of the gas installation had been checked after connecting the boiler to the system.**
- Boiler may be installed and operated only in a room where all building works have been completed. It is not allowed to install and operate the boiler in a room where building works are still in progress.
- The cleanliness of air in a room where the boiler will be installed must meet the same requirements as for rooms designer for people.
- There should be installed appropriate filters on a central heating system and gas system . Filters are not included in a basic boiler equipment.
- An example of connecting a boiler to these systems is presented on fig. 3.5.1.
- All defects caused by lack of filters on central heating or gas supply will not be repaired under guarantee.
- Central heating system must be thoroughly cleaned and rinsed, the procedure is described on p.3.5.2.
- To avoid malicious calcification process of flue gas - water heat exchanger and also for reduce a risk of other items damage, there should be:
 - the proper water preparation in C.H. circuit according to p.3.5.2, Proper water parameters in C.H. system allows for long term operation maintaining its high efficiency, what leads to lower costs of gas consumption,
 - proper tightness of central heating system ensured by avoiding frequent refilling it with water,
- Complaints caused by gas-water heat exchanger calcification will not be repaired under guarantee.
- The initial start-up of the boiler as well as its repairs, adjustments and maintenance works must be performed only by AUTHORISED SERVICE COMPANY.
- The boiler must be operated only by an adult.
- Do not do any repairs and modifications by yourself.
- Do not cover any ventilation grilles.
- Do not keep in the vicinity of the boiler any containers with flammable, aggressive and corrosive liquids and other similar substances.
- Any failures that are result of operation discordant to recommendations included in this instruction manual cannot be subject to warranty claims.
- Manufacturer is not responsible for any failures being the result of faults during the process of installation and inobservance the regulations and instructions given by the manufacturer.
- Complying with recommendations given in this instruction manual ensures a long, reliable and safe operation of the boiler.

NOTICE!

When you smell gas:

- do not use any electrical switches that could cause any spark,
- open the door and windows,
- shut down the main gas valve,
- immediately contact your gas supplier.

In case of any failure you should:

- disconnect the boiler from a power source,
- shut down the gas supply valve,
- cut off a water supply and drain a water from the boiler and whole central heating system as well (when there is any risk of freezing of the system),
- drain the water from the system in any case of leakage that could cause a flood ,
- contact the nearest **AUTHORISED SERVICE COMPANY** or the producer.

¹⁾ 'Qualified person'- person that has all required technical qualifications in an area of doing all the works necessary to connect appliances to the gas mains, central heating system and flue gas duct, accordingly to local regulations.

WARNING!

Operational instruction during the start-up of the condensing boilers
The instruction should be used after every draining water in the boiler
i.e. during the renovation of C.H. installation or repair of the boiler.

Read carefully the instruction manual before filling the boiler with water

1. Fill the heating circuit with water and vent the radiators before start.
2. Check the correctness of connection the electrical cords of boiler (network 230 V/50 Hz) to the network:
 L- brown; N – blue; PE – yellow-green. **Do not change the cords L and N!**
 In case of change the cords, the boiler will enter in failure state, on display will occur an error code E01.
 Mark the cords properly when connected directly to the electrical box, to eliminate the possibility of exchange.
3. **Close the gas cut-off valve!**
4. **Open valves which cut-off the boiler from C.H. circuit.**
5. Remove the front cover of the boiler by unscrewing the relevant fixing screws (fig. 1).
6. Remove the front cover of the combustion chamber (fig. 2).
7. Loosen the stopper on the automatic air-vent of the pump. In order to protect the pressure transducer from water, point the outlet of stopper to the right (fig. 3).
8. Turn on the device. Wait until the start procedure, testing the internal subassembly's and ventilating the combustion chamber will end (time about 10 – 30 sec.)
9. Fill the boiler with water by using the filling valve (in case of system boilers – the filling valve is mounted on C.H. installation, in case of combi boilers – the filling valve is on the boiler's equipment – see p.3.5). Open the filling valve slowly to protect the boiler's and the C.H. installation's components against the results of a hydraulic shock.
10. During filling the boiler with water control the pressure by using the analogue manometer mounted on the boiler's front cover or the electronic manometer by reading the pressure from display of the controller (depending on the boiler's type). Shut off the filling valve after reaching the pressure of 1,0 – 1,5 bar.
Note: in some models of boilers, after end of the start procedure, the "support the venting of boiler" function starts. This function is signalized on the controller display by "Po" and lasts 3 min. Start the "support the venting" function requires the water pressure above 0,5 bar, that's why during this procedure check and fill up the water pressure in the boiler, it is best to maintaining it the range of 1,0-1,5 bar.
11. Set the operating mode on WINTER according to the boiler instruction. If to the boiler controller has been connected the room thermostat than increase the desired temperature; the boiler should start operating in C.H. mode.
12. Because the gas valve outside the boiler is closed, the boiler will stop operate (E01 error code – a lack of gas). It allow for continuous pump operation and for removal of the air flowing in with water from the installation and for continuous water flow through the heat exchanger. Leave the boiler in this state for 2-3 min.
13. Delete E01 code by "reset" button and set the boiler controller on pressure reading mode (in version without an analogue manometer). During the first days of boiler operating it is recommended to set the water pressure in C.H. circuit on 1,8-2,0 bar. It will facilitate the work of the air-vent on the boiler pump and on the components of C.H. circuit. **
14. **Unscrew the gas valve** and delete E01 code again.
15. Set the desired operating parameters of the boiler according to the instruction manual. ***
16. Check the water pressure in C.H. circuit and if it's necessary fill the pressure up to the right level.

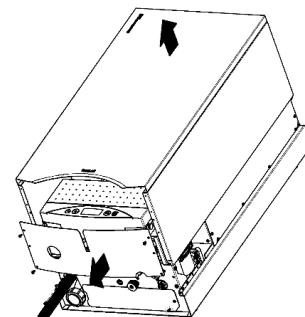

Fig. 1

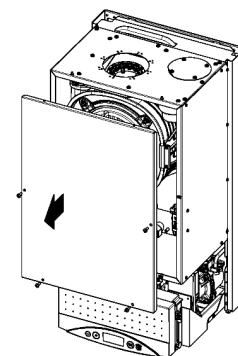

Fig. 2

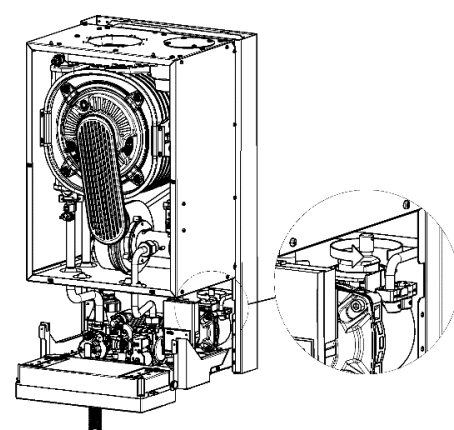

Fig. 3

* Depending on the size of C.H. circuit time of filling the boiler with water can be different. It is recommended to earlier fill the C.H. installation with water.

** In home C.H. circuits the nominal operating pressure should be set on 1,2-1,6 bar.

*** Note! The boiler is factory set on operating in the radiator heating. In case of the floor heating, the boiler control system shall be adapted to other operating parameters. This action is performed by Authorized Service Company.

Table of Contents

1. INTRODUCTION	3
2. BOILER DESCRIPTION	3
2.1. TECHNICAL SPECIFICATION	3
2.1.1. <i>Technical features</i>	3
2.2. DESIGN AND TECHNICAL SPECIFICATIONS OF THE BOILER	3
2.2.1. <i>Main units of the boiler</i>	3
2.2.2. <i>Technical data</i>	5
2.3. PROTECTION EQUIPMENT	6
2.4. OPERATION DESCRIPTION	6
2.4.1. <i>Way of heating the water for central heating system</i>	6
2.4.2. <i>Temperature regulation dependent on external temperature</i>	6
2.4.3. <i>Method of D.H.W. heating in combi boilers</i>	7
2.4.4. <i>The way of heating the water in system boiler ECOCONDENS SILVER PLUS cooperating with domestic water tank</i>	7
2.4.5. <i>Operation of the pump with adjustable speed</i>	8
3. BOILER INSTALLATION	9
3.1. REQUIREMENTS OF BOILER INSTALLATION	9
3.1.1. <i>The regulations on the water installation, gas and the flue gas system</i>	9
3.1.2. <i>Regulations related to the room</i>	9
3.1.3. <i>Requirements for electrical installation</i>	9
3.2. PRELIMINARY CHECK ACTIVITIES	10
3.3. MOUNTING THE BOILER ON THE WALL	10
<i>Fig. 3.3.1 Installation dimensions of boiler ECOCONDENS SILVER PLUS</i>	10
3.4. CONNECTION TO THE GAS INSTALLATION	10
3.5. CONNECTION OF THE BOILER TO A WATER SYSTEM OF CENTRAL HEATING	10
<i>Fig. 3.5.1 Boilers installation requirements</i>	11
3.5.2 <i>System cleaning and water treatment for the C.H. filling</i>	11
3.6. CONNECTION OF THE BOILER TO A DOMESTIC HOT WATER SYSTEM	12
3.7. CONDENSATE OUTLET	12
3.8. FLUE GAS OUTLET	12
3.8.1. <i>The ways of mounting adapters (elbows connection) to the boiler type</i>	12
3.8.2. <i>Horizontal outlet of air-flue system through the wall or on the roof</i>	13
3.8.3. <i>Vertical outlet of air-flue gas system through the roof</i>	13
3.8.4. <i>Connecting to a common chimney duct system, consisting of a duct for air inlet and flue gas outlet duct</i>	13
3.8.5. <i>Flue gas air outlet and air inlet by two separate tubes</i>	14
3.8.6. <i>Reduction of the maximum length of the air-flue system by changing the flow direction</i>	15
3.9. CONNECTION OF ADDITIONAL DEVICES	15
<i>Fig.3.9.1 Electrical terminals of controller - a back view</i>	15
3.9.2 <i>Connection of a room temperature regulator</i>	15
3.10. CONNECTING THE OUTSIDE TEMPERATURE SENSOR	15
4. BOILER ADJUSTMENT AND PRELIMINARY SETTING	15
4.1. INTRODUCTORY REMARKS	15
4.2. ADJUSTING THE BOILER TO COMBUST ANOTHER TYPE OF GAS	15
4.3. BOILER ADJUSTMENT	16
4.3.1. <i>Gas flow regulation in the boiler (without using the flue gas analyzer)</i>	16
4.3.2. <i>Adjustment of the boiler with a gas analyzer</i>	16
4.4. FAN CHARACTERISTICS	17
<i>Fig.4.4.1. CHARACTERISTICS OF THE FAN- TYPE NG40M</i>	17
5. STARTUP AND OPERATION OF THE BOILER	17
5.1. INITIAL STARTUP OF THE BOILER	17
5.2. INCLUSION AND OPERATION	17
5.3. OPERATING MODES OF THE CONTROLLER	18
5.4. SIGNALIZATION OF OPERATION STATES AND DIAGNOSIS	18
5.4.1. <i>Signalisation of the start of heating in CH or DHW system</i>	19
5.4.2. <i>Signalisation of anti-freezing function operation in STAND BY mode</i>	19
5.4.3. <i>Displaying the water pressure in CH installation</i>	19
5.4.4. <i>Displaying parameters</i>	19
5.4.5. <i>DHW heating blockade indicator for one-function boilers</i>	19
5.4.6. <i>Support the venting of heating system</i>	19
5.5. CHANGING THE CH OR DHW TEMPERATURE SETTINGS	19
5.5.1. <i>Temperature settings in CH circuit</i>	19
5.5.2. <i>Temperature settings in DHW circuit</i>	20
5.6. CONTROLLER CONFIGURATION – BOILER PARAMETERS SETTING	20
5.6.1. <i>Programming Mode entering</i>	21
5.7. PAUSE IN BOILER OPERATION	21
5.8. DIAGNOSIS	21
5.8.1. <i>Signalisation of error codes during the emergency procedures implementation</i>	21
5.8.2. <i>Signalisation of error codes in emergency situations without locking</i>	21
5.8.3. <i>Signalisation of emergency switching off with locking</i>	21
5.8.4. <i>Error list</i>	22
6. MAINTENANCE, INSPECTIONS, CHECKING OF THE OPERATION	23
6.1. INSPECTION AND MAINTENANCE	23
6.1.1. <i>Maintenance of the combustion chamber, burner, electrode</i>	23
6.1.2. <i>Cleaning the condensate siphon</i>	23
6.1.3. <i>The pressure in the expansion vessel</i>	23
6.1.4. <i>Maintenance of the flue water-water heat exchanger, item.21</i>	24
6.1.5. <i>Checking the temperature sensors</i>	24
6.1.6. <i>Checking the water pump operation</i>	24
6.1.7. <i>Ionisation current measurement</i>	24
6.2. REPLACING A DAMAGED CONTROL BOARD IN THE CONTROL PANEL	25
6.3. THE MAINTENANCE OPERATIONS TO BE PERFORMED BY THE USER	26
6.4. RANGE OF TECHNICAL MAINTENANCE PERFORMED BY SERVICE COMPANY	26
7. BOILER EQUIPMENT	26

1. INTRODUCTION

Combi condensing boiler is designed for supplying central heating systems and for heating domestic water.

In this manual there are described below mentioned types of ECOCONDENS SILVER PLUS - combi boilers designed for supplying a central heating systems and for heating domestic water in instantaneous water-water heat exchanger:

type ECOCONDENS SILVER PLUS -20

type ECOCONDENS SILVER PLUS -25

type ECOCONDENS SILVER PLUS -35

and ECOCONDENS SILVER PLUS – system boilers designed for supplying a central heating system and heating domestic water in separately connected water tank.

Adaptation of the following types of boilers to work with the tank needs to be made by **AUTHORISED SERVICE COMPANY**.

type ECOCONDENS SILVER PLUS -20

type ECOCONDENS SILVER PLUS -25

type ECOCONDENS SILVER PLUS -35

ECOCONDENS SILVER PLUS boilers take the air for combustion process from outside the room (in which combustion circuit is sealed) with respect to the residential area of the building in which it is installed - type of installation: C₆₃, or take the air for combustion process from the room that meets appropriate conditions (required by law) - type of installation: B₂₃.

Further information regarding the type – according section 3.8 and PN-EN 15502-2-1:2013-04

2. BOILER DESCRIPTION

2.1. Technical specification

2.1.1. Technical features

- Electronic fluent flame modulation for central heating system and domestic hot water;
- Electronic ignition with ionization flame control;
- Adjustable boiler power;
- Regulation of heating water and domestic water temp.;
- Soft ignition function;
- Inlet gas pressure stabilisation;
- Adopted to cooperate with closed circuit in CH system;

2.2. Design and technical specifications of the boiler

2.2.1. Main units of the boiler

Descriptions for fig. 2.2.1.1 ÷ 2.2.1.3

- | | |
|---------------------------------------------------------------------------------------------|---------------------------------------------------------------------------------------|
| 5. Fan, | 18. NTC sensor of heating water -supply |
| 7. Pump, | 19. Heating water pressure transducer, |
| 8. Gas unit | 20. Air -vent |
| 10. Flame control/ Ignition electrode, | 21. Plate water-water heat exchanger, |
| 11. Burner, | 22. Filling valve of installation |
| 12. 3-way valve, | 25. Safety valve - 3 bar, |
| 13. Flue gas-water heat exchanger | 26. Domestic water flow sensor |
| 15. Temperature limiter as a protection against exceeding the upper limit water temperature | 27. NTC sensor of domestic water temperature |
| 16. Thermal fuse of flue gas, | 28. NTC temperature sensor of heating water - return (only in boilers with PWM pumps) |
| 17. Expansion vessel | 29. Siphon |
| | 30. Mixing unit |
| | 33. Drain valve |

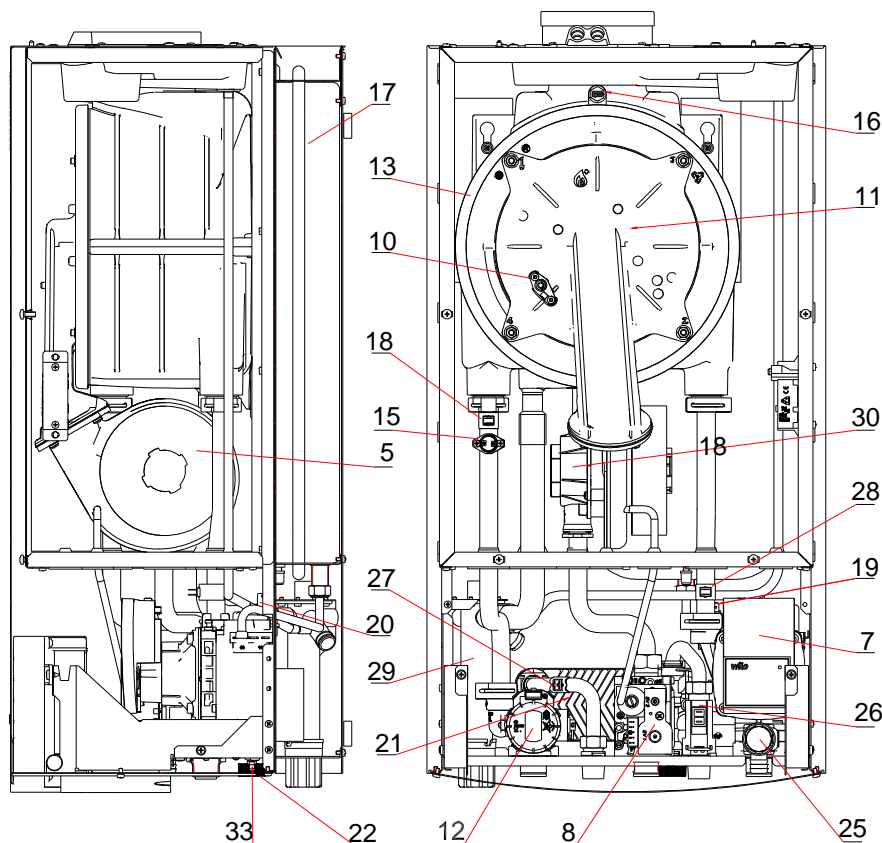

Fig.2.2.1.1. Location of elements in combi boiler ECOCONDENS SILVER PLUS

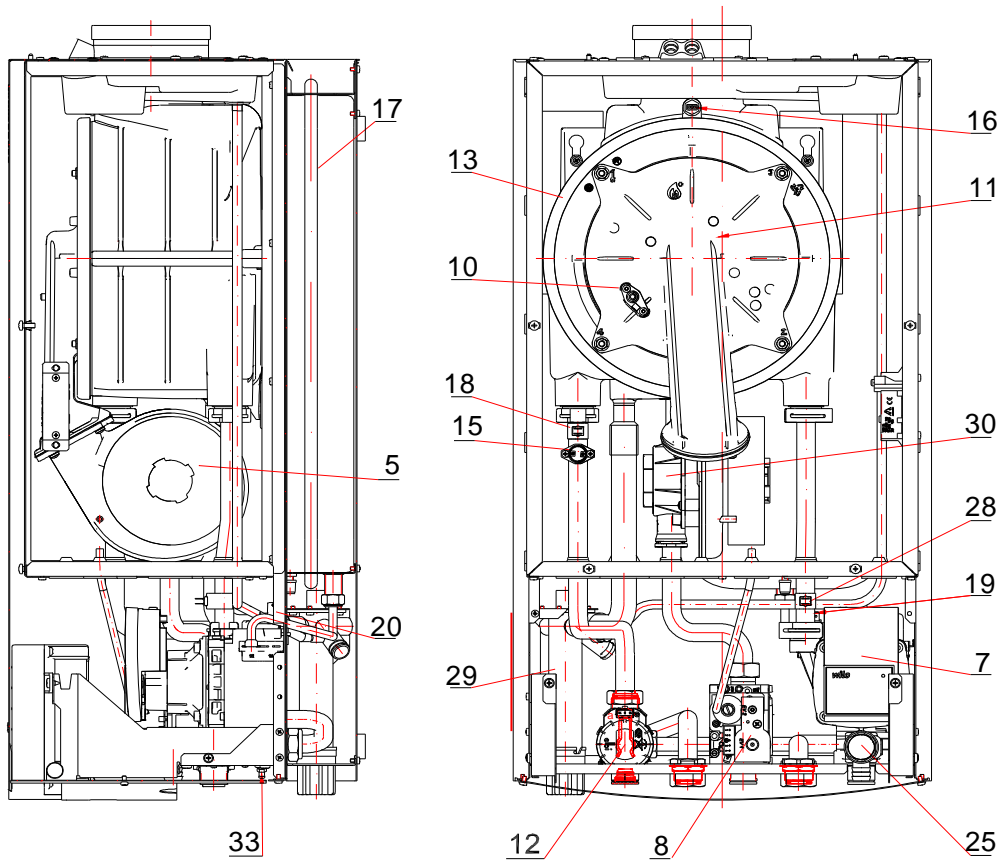

Fig.2.2.1.2. Location of elements in system boiler: ECOCONDENS SILVER PLUS

Only Fig. 2.2.1.3.

- 1. Switch of boiler function selection
- 2. Temperature selector (c.h. or d.h.w.)

- 3. Heating water, domestic water and static pressure temperature display with error codes diagnostic
- 4. Control panel
- K1. ON/OFF, reset

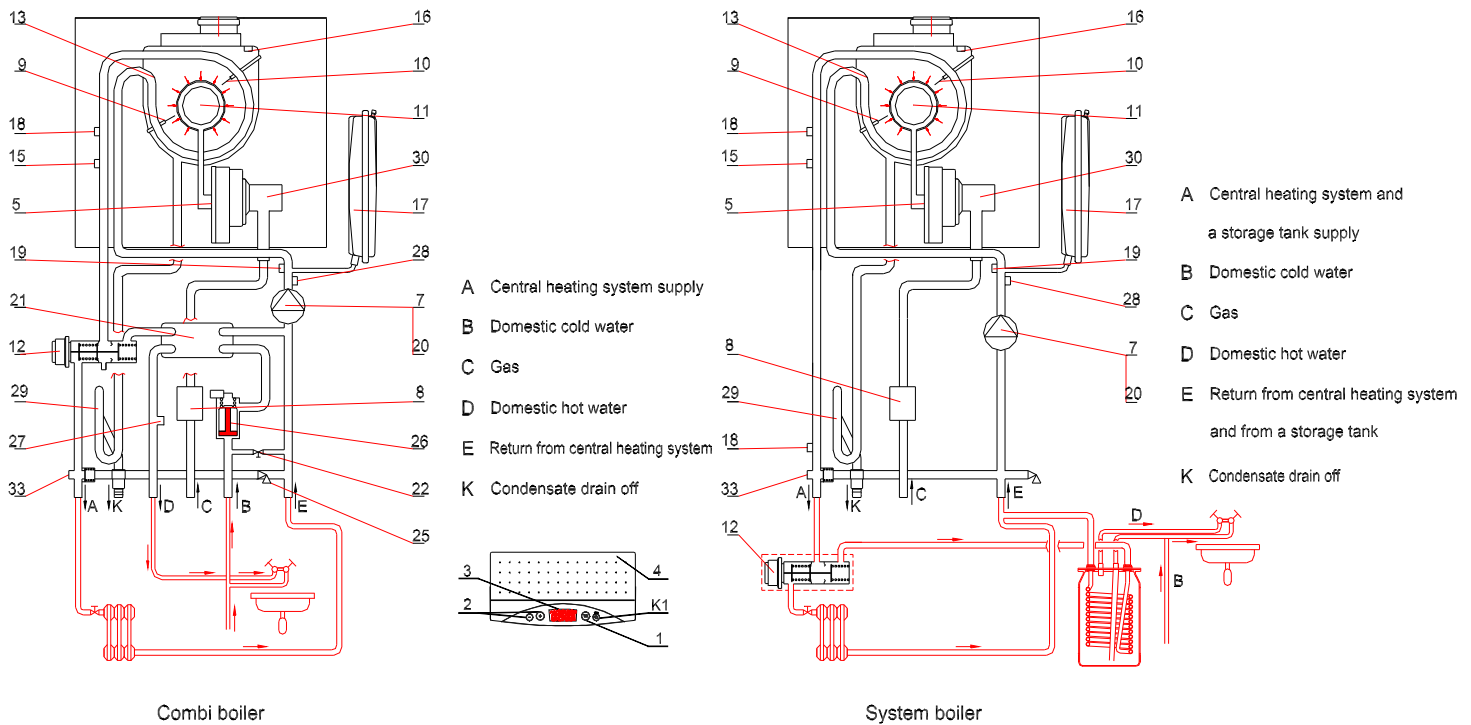

Fig.2.2.1.3. Scheme of boiler operation

2.2.2. Technical data

Parameter	Unit	SYSTEM BOILER: ECOCONDENS SILVER PLUS			COMBI BOILER: ECOCONDENS SILVER PLUS		
		-20	-25	-35	-20	-25	-35
		Size					
Energetic parameters							
Central heating circuit							
Boiler thermal power at 80/60°C (modulated)	kW	2.7 ÷ 20.0	3.9 ÷ 24.0	4.1 ÷ 34.7	2.7 ÷ 20.0	3.9 ÷ 24.0	4.1 ÷ 34.7
Boiler thermal power at 50/30°C (modulated)	kW	3.0 ÷ 22.0	4.3 ÷ 26.5	4.5 ÷ 38.2	3.0 ÷ 22.0	4.3 ÷ 26.5	4.5 ÷ 38.2
Heat load	kW	2.8 ÷ 20.4	4.0 ÷ 24.6	4.2 ÷ 35.6	2.8 ÷ 20.4	4.0 ÷ 24.6	4.2 ÷ 35.6
The efficiency of the boiler at nominal load and average boiler water temp. 70 °C	%	97.6	98.0	98.0	97.6	98.0	98.0
The efficiency of the boiler at partial load and return water temperature 30 °C	%	107.9	108.7	109.0	107.9	108.7	109.0
Modulation range	%	13-100	16-100	12-100	13-100	16-100	12-100
Seasonal space heating energy efficiency η_s	%	91	92	92	91	92	92
Seasonal space heating energy efficiency class		A					
Useful heat output :							
- at rated heat output P_d	kW	20.0	24.0	34.7	20.0	24.0	34.7
- at 30% of rated heat output P_1	kW	6.0	7.2	10.4	6.0	7.2	10.4
Useful efficiency :							
- η_d	%	88.0	87.9	87.8	88.0	87.9	87.8
- η_1	%	97.0	96.9	96.5	97.0	96.9	96.5
Nominal kinetic pressure in front of the boiler for gas: 2E-G20, 2H-G20 3B/P-G30, 3P-G31	Pa (mbar)	2000 (20); 2500 (25); 2000 (20); 1300 (13) 2800 ÷ 3000 (28 ÷ 30); 3000 (30); 3700 (37); 5000 (50)					
Maximum water pressure	MPa (bar)	0,3 (3)					
Max temperature (central heating)	°C	95					
Standard adjustable temperature	°C	40 ÷ 80					
Reduced adjustable temperature	°C	25 ÷ 55					
Lift of the pump at flow 0	kPa (bar)	70 (0,7)			70 (0,7)		
Domestic hot water circuit							
Nominal heat output of the boiler at temp. 80/60°C	kW	-----			2.7 ÷ 25	3.9 ÷ 30.0	4.1 ÷ 40.0
Nominal heat load	kW	-----			2.8 ÷ 25.6	4.0 ÷ 30.7	4.2 ÷ 41.0
The efficiency of the boiler at nominal load and average boiler water temperature of 70°C	%	-----			97.6	98.0	98.0
Water heating energy efficiency class					A	A	A
Load profile					L	XL	XL
Water pressure	MPa (bar)	-----			0.01 (0.1) ÷ 0.6 (6)		
Min water flow	l/min	-----			2.0		
Max water flow (flow limiter)	dm ³ /min	-----			-----	-----	-----
Range of water temperature regulation	°C	30 - 60					
Flow of domestic water for $\Delta t=30K$	dm ³ /min				12	14	19
Environmental protection							
Emissions of nitrogen oxides	mg/kWh	21	24	29	21	24	29
Emission of NO _x (natural gas)	class	5					
The pH of the condensate		natural gas - 5					
Sound power level L_{WA}	dB	48	48	48	48	48	48
Hydraulic parameters							
Expansion vessel capacity	dm ³	6					
Water pressure in expansion vessel	MPa (bar)	0.08 _{±0.02} (0.8 _{±0.2})					
Electric parameters							
Type and supply voltage	V	~ 230 ±10%/ 50Hz					
Degree of protection		IP44					
Power consumption	W	110					
Standby mode power consumption P_{sb}	kW	0.005					
Electricity consumption :							
- at full load $e_{l_{max}}$	kW	0.05	0.05	0.05	0.05	0.05	0.05
- at part load $e_{l_{min}}$	kW	0.02	0.02	0.02	0.02	0.02	0.02
Maximum nominal current value of output terminals	A	2					
Controller classification according to PN EN 298		F-M-C-L-X-K					
Type of flame sensor		ionization					
The parameters of flue gas							
Fan characteristics		→ section 4.4 of this manual					
Flue gas mass flow at full load	kg/h	51.4	72.3	90.4	51.4	72.3	90.4
Flue gas mass flow at partial load	kg/h	5.4	9.5	9.6	5.4	9.5	9.6
The minimum flue gas temperature at minimum thermal power	°C	44	34.3	34.3	44	34.3	34.3
The maximum flue gas temperature at maximum thermal power	°C	61	66.9	66.7	61	66.9	66.7
Time parameters							
Time of central heating pump rundown	s	180					
Time preventing the anti-cyclical startup of the boiler (Anti-cycling time)	minutes	3-60					
Time of domestic hot water pump rundown	s	20-180					
Protection against pump and valve blocking	h/s	the pump turns on for 180 seconds every 24 hours the pump and three way valve turns on for 15 seconds every 48 hours					

Assembly dimensions							
Connection to the chimney duct (→ section 3.8. and table 7.1.)	mm	Coaxial $\Phi 80/\Phi 125$, Coaxial $\Phi 60/\Phi 100$ or 2 separate $\Phi 80 \times \Phi 80$					
Connection of heating water (CH) and gas	inch	G3/4					
Connection of DHW	inch	G3/4			G1/2		
Dimensions	mm	785x400x 334	785x400x 334	785x400x 334	785x400x 334	785x400x 334	785x400x 334
Boiler weight	kg	31.5	32.5	37.5	33.5	34.5	39.5

The manufacturer reserves the right to make changes in the construction of the boiler, which are not mentioned herein and have no influence on the technical and functional characteristics of the product.

2.3. Protection equipment

- Protection against gas outflow
- Protection against explosive gas switching on
- Protection against exceeding the max temperature in the heating water system
- Protection against exceeding the upper limit of heating water temperature
- Protection against water pressure increase (1-st degree)- electronic
- Protection against water pressure increase (2-nd degree)- mechanical
- Protection against drop of water pressure
- Protection against water overheating
- Anti-freezing protection of the boiler
- Protection against the pump blockade
- Monitoring of the correct operation of the fan. Fan failure is detected if the current fan speed is different from that expected by the driver of the boiler.
- Protection against exceeding the upper limit temperature of flue gas (115°C).

Errors which do not require manual reset will cause return of the boiler to the normal operation after automatic disappearance of failure → section 5.8 - boiler diagnostics.

NOTICE!
In case of noticing repeated emergency boiler shut-down by any of the protection it is necessary to contact an Authorized Service Company in order to check the reason of boiler switching off and to repair it.
It is forbidden to make any unauthorized modifications in the protection system.

2.4. Operation description

2.4.1. Way of heating the water for central heating system

The boiler switches on if the heating water temperature drops about 5 degrees below the set temperature - as described in section 5.5.1 and the room thermostat gives the signal to heat. Then the following conditions occur simultaneously:

- power supply of the three-way valve (item 12 towards the central heating installation),
- pump supply (→item 7),
- fan supply (→item 5),
- the sequence of ignition,
- then the driver starts the fan speed regulation so as to obtain the desired temperature of heating water

The boiler switches off when the room temperature control unit is signaling desired temperature in the room or when heating water temperature is higher than desired (by value of hysteresis see P20). In this case the "L3" is shown on the display. After switching off the burner, pump runs for about 180 s, and fan for 15 s.

Restart of the boiler will be done automatically under the following conditions simultaneously:

- heating water temperature is lower by 5°C than the set temperature,
- room temperature control unit provides the signal "HEAT",
- **180 seconds have passed**, waiting time determined by parameter P25 have passed (default 3 minutes) if L3 was displayed.

The list of driver parameters according to Table 5.6.

2.4.2. Temperature regulation dependent on external temperature

If an external temperature sensor has been connected the controller detects it automatically and goes to the weather function mode. Controller adjusts the heating water temperature making it dependent on outside temperature and coefficient of the slope of the heating curve K_t " and parameter P22 → diagram shown on the Fig. 2.4.2.1 and 2.4.2.2
 Changing the value of the coefficient K_t is described in Section 5.5.1.1.

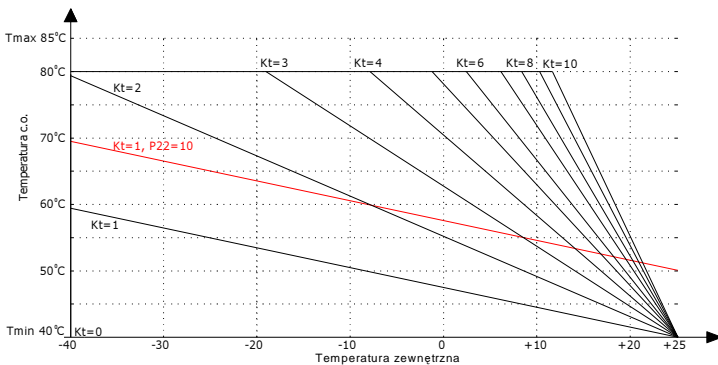

Fig.2.4.2.1 Diagram of the heating curve (standard heating)

Notice:

- 1) for value $T_{out} \geq 25^\circ\text{C}$ and $P22=0$ designed temp. $T_{c.h.}$ is always equal to T_{min} .
- 2) at max. coefficient K_t and $P22=0$, T_{max} is reached when $T_{out} \leq 10^\circ\text{C}$.
- 3) T_{max} will not exceed 80°C for standard heating and 55°C for floor heating regardless of the value $P22$

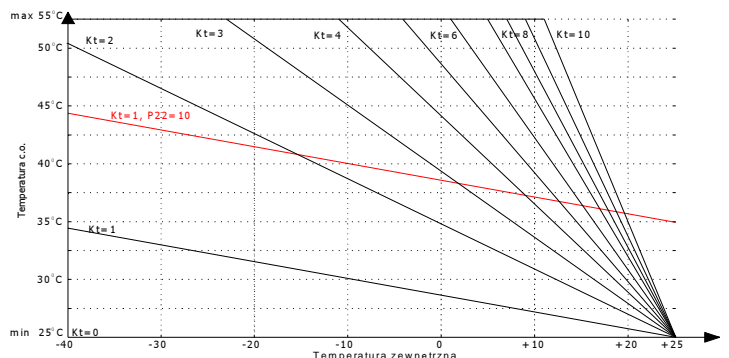

Fig.2.4.2.2 Diagram of the heating curve (floor heating)

4) In case, when weather regulator works in autonomic mode (parameter P26=2), RT input is treated as an input for choice of time of day: DAY (contact open) NIGHT (contact closed). During NIGHT time, calculated temp. T_{CH} is reduced by the P28 parameter value. Boiler starts heating CH water if the outdoor temperature is lower than P27 parameter value. Boiler stops heating CH water if the outdoor temperature is higher than P27 parameter value at least 3 hours.

5) If P26=0, then weather regulator doesn't work, it is only outdoor temperature measurement.

2.4.3. Method of D.H.W. heating in combi boilers

Combi boiler heats the water in a instantaneous way. Water temperature is set using the buttons +/- (→p.5.5.2) in the range 30°C to 60°C. The water temperature at the outlet depends on water temperature at the inlet.

Water flow shall be determined by draw-off valve in the outlet.

In this mode the water heating demand occurs when the flow sensor turns on at the value above 2.0 l/min (ends at a flow < 1.5 l/min.)

Then follows the sequence:

- switching the power of the 3-way valve (→item 12) in direction of the water-water heat exchanger supply for the pump (→item 7),
- after flame detection and the end of startup sequence, signal from the NTC sensor (DHW) adjusts the fan speed to reach the desired temperature of domestic hot water →item 27

Central heating hot water flows through the water-water heat exchanger segments and heats the water. The heated water is directed to the point of its collection.

NOTICE: In the case of a lower fan rotation range caused by low water consumption, there is a water temperature increase. Turning off the gas flow to the main burner will come when the DHW temperature exceeds 65°C.

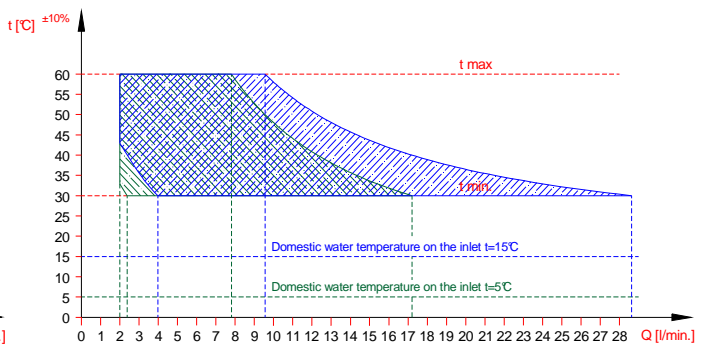
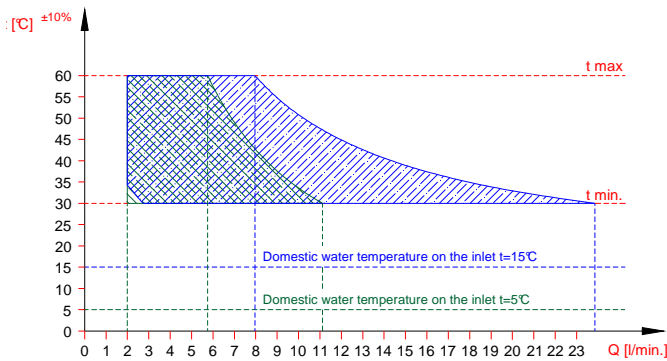

g. 2.4.3.1. Diagram of domestic water temperature at the boiler inlet at thermal Power of 25kW depending on the water flow rate.

Fig. 2.4.3.2. Diagram of domestic water temperature at the boiler outlet at thermal power of 30kW depending on the water flow rate.

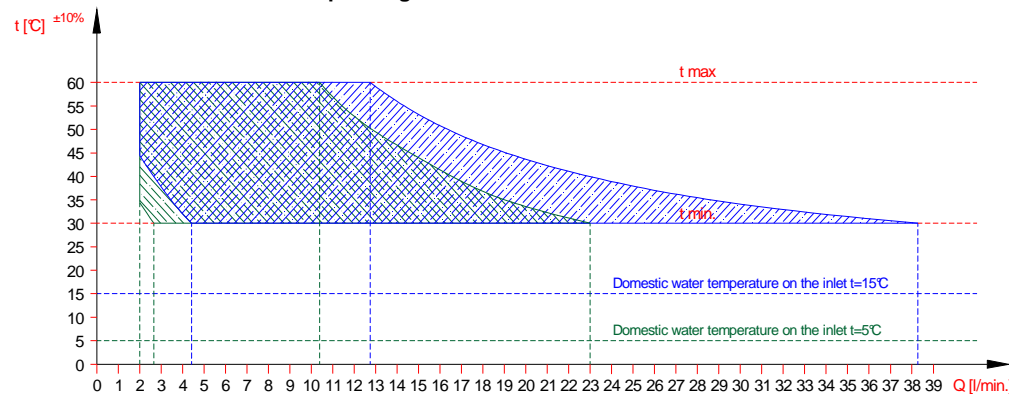

Fig. 2.4.3.3. Diagram of domestic water temperature at the boiler outlet at thermal power of 40kW depending on the water flow rate.

2.4.4. The way of heating the water in system boiler ECOCONDENS SILER PLUS cooperating with domestic water tank.

The boiler may cooperate with domestic water tank type Termet-120, Termet-140 and ZWU200/N. These water tanks are offered by TERMET company. Adjustment and display of domestic water temperature are done by the control panel of the boiler. Boilers are factory designed for cooperation with domestic hot water tanks.

The process of heating the domestic water:

When the water temperature sensor detects the temperature lower by 5°C of the set value (look p.5.5.2) then the process of pumping the water to the central heating system will be stopped. Heating the domestic water with the boiler cooperation with the tank of domestic hot water is as follows:

- water temperature sensor detects the temperature lower by 5°C of the set value (for example as a result of unscrewing the tap);
- boiler controller switches the three-way valve to pump water to a short circuit, while giving a signal to the spark generator and gas valve →item 8;
- heating water with temperature described by parameter P21 (default 75°C) flows through the coil of tank (short circuit);
- after exceeding by 1°C set water temperature in the tank the boiler controller switches the 3-way valve for long circuit and after meeting below mentioned conditions the heating water is pumped into the central heating system:
 - heating water temperature is lower by 5°C of the set temperature
 - room temperature regulator gives a signal "HEAT".

The temperature of hot water at the point of consumption may be different from the set value, and therefore it is advisable to install a mixing valve for domestic hot water systems.

Water heating in the storage tank is active when the electrical bridge is mounted on the TZ input (→ Fig.3.9.1.)and when set temperature value is higher or equal to the minimum value. After setting the value lower than the

minimum, the tank is switched off. This does not apply for frost protection function.

NOTE: To eradicate legionella bacteria in the storage tank, the boiler is turned on every 168h to work with the tank and heats water to 65°C.
If legionella function does not work in automatic mode, the user at any time can manually initiate a single cycle of tank heating to 65°C.

2.4.4.1 Manual initiation of disposable tank overheating - Anti-legionella function in manual mode

* (applies to the boilers with tanks):

When the boiler is operating in SUMMER mode:

Press the button  twice. After first pressing the button, the display shows (ready to modify) option of CH setting. Next pressing displays the symbols characteristic of Legionella Function: a flashing key symbol, right field dimmed, in the left field you can see DHW temperature and the symbol MAX placed above it.

When the boiler is operating in WINTER mode:

Please press the button  three times. After first pressing the button, the display shows (ready to modify) option of CH setting. Next (second) pressing displays the symbols characteristic of Service Function. Next pressing displays the symbols characteristic of Legionella Function: a flashing key symbol, right field dimmed, in the left field you can see DHW temperature and the symbol MAX placed above it.

In both modes of operation:

To activate the Legionella Function hold the button "+" for 2 seconds. After activation Legionella Function the symbol "key" will light up with solid light. To activate the Legionella you have about 3 seconds. After this time, or when you press the reset button the system goes to the normal mode characteristic for the selected operation mode.

During the implementation of Legionella Function, the temperature field is dimmed.

Completion of Legionella function is performed automatically or by pressing the reset button or the operation mode change.

2.4.5. Operation of the pump with adjustable speed.

In the boilers equipped with a pump with variable speed (PWM) during the work in DHW mode

- in two-function boilers the pump has maximum speed
- in one-function boilers the speed of the pump is determined by parameter P19

While heating water in C.H. system the controller regulates the pump according to:

For conventional PWM pump operation (parameter P 15 = 0):

PWM Pump (activation by parameter P12) works with a modulated speed in C.H. system activating by signal from RT (room temperature regulator). The rotational speed is adjusted in such a way that in cooperation with the modulator to achieve the value of ΔT (defined by parameter P13) between outgoing and return temperature of central heating system. There is maintained a priority to achieve and hold the set of temperature in central heating system. Minimum allowable rotation speed of the pump is determined by parameter P14. The maximum allowable rotation speed of the pump is determined by parameter P18

ECO mode (parameter P15 = 1):

PWM Pump (activation by parameter P12) works with a modulated speed in C.H. system activating by signal from RT (room temperature regulator). The rotational speed is adjusted in such a way that in cooperation with a modulator achieved value ΔT between outgoing and return temperatures of central heating system calculated on the basis of a preset ratio ECO (p.2.4.5.1). ECO factor is adjusted on the user interface in the range of 0.1 to 0.9. The default (optimal in most cases) value is 0.5. Selection of lower value results in lower gas consumption with less heat energy being placed into the room (simplified we decide what part of the radiator has to be warmed up). The user obtains the possibility of such a regulation of device to get the thermal comfort at minimum cost (less gas consumption, lower power consumption). The value 0,5 of the coefficient of ECO is the maximum value at which the control regardless of the temperature setting C.H. water seeks to meet the conditions of condensation (C.H. return temperature ≤ 55 °C). It is recommended to work the system at the ECO ratio in the range of 0.1 to 0.5. If increasing the C.H. setting cannot obtain adequate thermal comfort should gradually increase the value of the ECO. ECO factor equal to 0.9 practically corresponds to the traditional work of the pump without speed control.

Irrespective of the mode of operation:

Preserved is a priority to achieve and maintain the set temperature C.H. water. Minimum allowable rotation speed of the pump is determined by parameter P14. The maximum allowable rotation speed of the pump is determined by parameter P18

NOTE:

If the temperature sensor of return central heating water is damaged or is not connected, the pump works with a constant speed.

2.4.5.1 The expected value of T depending on the setting C.H. water and the coefficient of ECO.

The expected value of T depending on the setting C.H. water and the coefficient of ECO.

Standard heating (P8 = 0): Setting WG									
Eco	40°C	45°C	50°C	55°C	60°C	65°C	70°C	75°C	80°C
0,1	24	30	35	35	35	35	35	38	42
0,2	21	26	30	30	30	30	30	33	37
0,3	18	22	26	26	26	26	26	28	31
0,4	15	19	22	22	22	22	22	24	26
0,5	12	15	17	17	17	17	17	19	21
0,6	9	11	13	13	13	13	13	14	15
0,7	6	7	8	8	8	8	8	9	10
0,8	3	3	4	4	4	4	4	4	5
0,9	0	0	0	0	0	0	0	0	0

Floor heating (P8 = 1): Setting WG					
Eco	35°C	40°C	45°C	50°C	55°C
0,1	16	24	30	35	35
0,2	14	21	26	30	30
0,3	12	18	22	26	26
0,4	10	15	19	22	22
0,5	8	12	15	17	17
0,6	6	9	11	13	13
0,7	4	6	7	8	8
0,8	2	3	3	4	4
0,9	0	0	0	0	0

3. BOILER INSTALLATION

The boiler must be installed by an authorized service company accordingly with local regulations. After the boiler installation check the tightness of all connections of gas, water and flue gas system. Service company is responsible for the proper installation of the boiler. Installation of the boiler must be made so as not to cause any tension of the installation that may cause increased volume of work. After exploitation of the boiler, disassembled product transfer to a specialized unit for utilization.

3.1. Requirements of boiler installation

3.1.1. The regulations on the water installation, gas and the flue gas system

Water, gas and flue gas systems must meet local regulations as well as use of the gas, ventilation and flue gas installation.

Using of gas appliances, flues and ventilation by the user should be consistent with local requirements relating to the technical conditions of use the residential buildings.

Before installing the boiler the consent from the District Department of Gas, Chimney Sweep Company and Building Administration must be obtained.

Gas appliances supplied with liquefied gas must not be installed in room with a floor below ground level.

If you use liquefied gas 3B/P it is recommended that the temperature in a room where a gas cylinder will be operated is not less than 15°C.

3.1.2. Regulations related to the room

Requirements for premises where gas appliances are installed shall be in accordance with local regulations. The room where the boiler is to be installed should ensure the air supply and venting system necessary for gas combustion in accordance with local regulations. The location of ventilation should not cause the water freezing. The temperature in the room where the boiler is installed should be higher than 6°C.

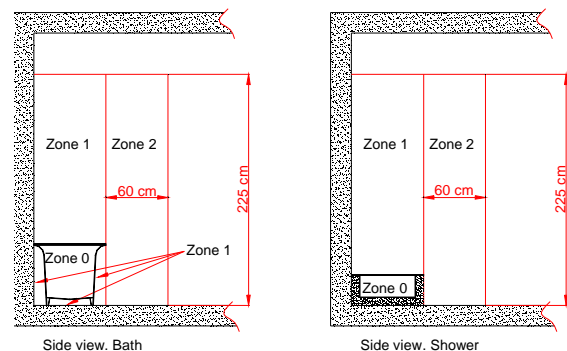

The room should be protected against freezing, free from dust and aggressive gases.

It is forbidden to install the device in a laundry rooms, drying rooms and in varnish, cleaners, solvents and sprays storages.

Boiler with a thermal capacity above 30 kW should be installed in a technical room.

Place of installing a boiler in a room equipped with bath or shower with a pool and the way of connecting it to the electrical system- in accordance with the requirements of HD 60364-7-701. The device covered by this instruction has a degree of electrical protection provided by the housing IP44. Boiler equipped with power cord with a plug can be installed in zone 2 or further - must not be installed in zone 1.

In zone 1 can be installed only if it is permanently connected to a power source in accordance with HD 60364-7-701.

Fig. 3.1.2.1. The zones dimensions in areas containing a bath or shower with a pool

3.1.3. Requirements for electrical installation

The boiler has been designed for operation with single-phase alternating current with rated voltage of 230 V/50 Hz.

The boiler has been designed as a "class I" device and must be connected to an electrical outlet with ground terminal in accordance with PN- IEC 60364-4-41.

The main socket from which boiler is powered must complies with PN-IEC-60364-6-61:2000

Pay attention on correctly connecting the power cord. If power cord is connected incorrectly:

- the boiler enters in failure state
- on display occurs E01 (→ item 5.8.4)

In this case change cords "L" and "N" in the socket. When the correct connection is detected, the boiler unlocks automatically. The boiler ECOCONDENS SILVER PLUS has a degree of electrical protection provided by the housing - IP44.

In case the boiler is permanently connected to the power supply the electrical installation should be equipped with means of disconnecting the boiler from the power source, it should be execute by junction box. The junction box must be equipped with protection degree appropriate for the defined assembly zone.

In order to connect the boiler to the junction box, it is recommended to:

- cut the power cord to a suitable length for connection to the box
- pull off cable insulation
- connect wire ends using soldering or tighten cable-end sleeve with appropriate diameter

This prepared cables connect according to the following diagram.

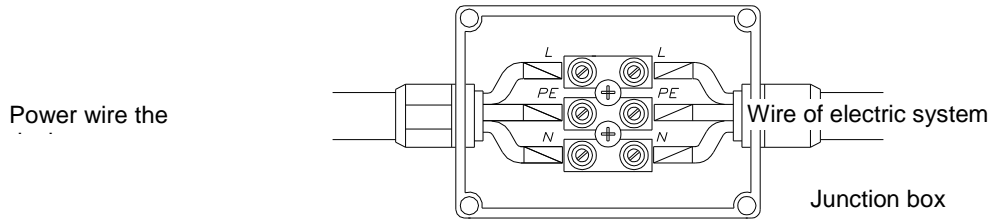

Fig 3.1.3.1 Wire colors: L – brown; N – blue; PE – yellow-green

3.2. Preliminary check activities

Before starting the installation work, check:

- whether the boiler is factory designed for the type of gas supplied from the gas system. The type of gas which the boiler is adjusted to is specified on the rating plate on the cover of the boiler;
- whether the water system and radiators have been properly rinsed with water in order to remove rust, fillings scale, sand and other dusts that could disturb the proper operation of the boiler (for example increase the water flow resistance in central heating system) or to pollute the heat exchanger,
- whether the mains voltage has a value of 230V and that the socket has an efficient safety contact (complies with PN-IEC-60 364-6-61: 2000).

3.3. Mounting the boiler on the wall

Hang the boiler on hooks fastened durably in the wall using a beam placed in upper part of the boiler. The boiler shall be so located as to permit the eventual repair without any need to dismantling from the installation.

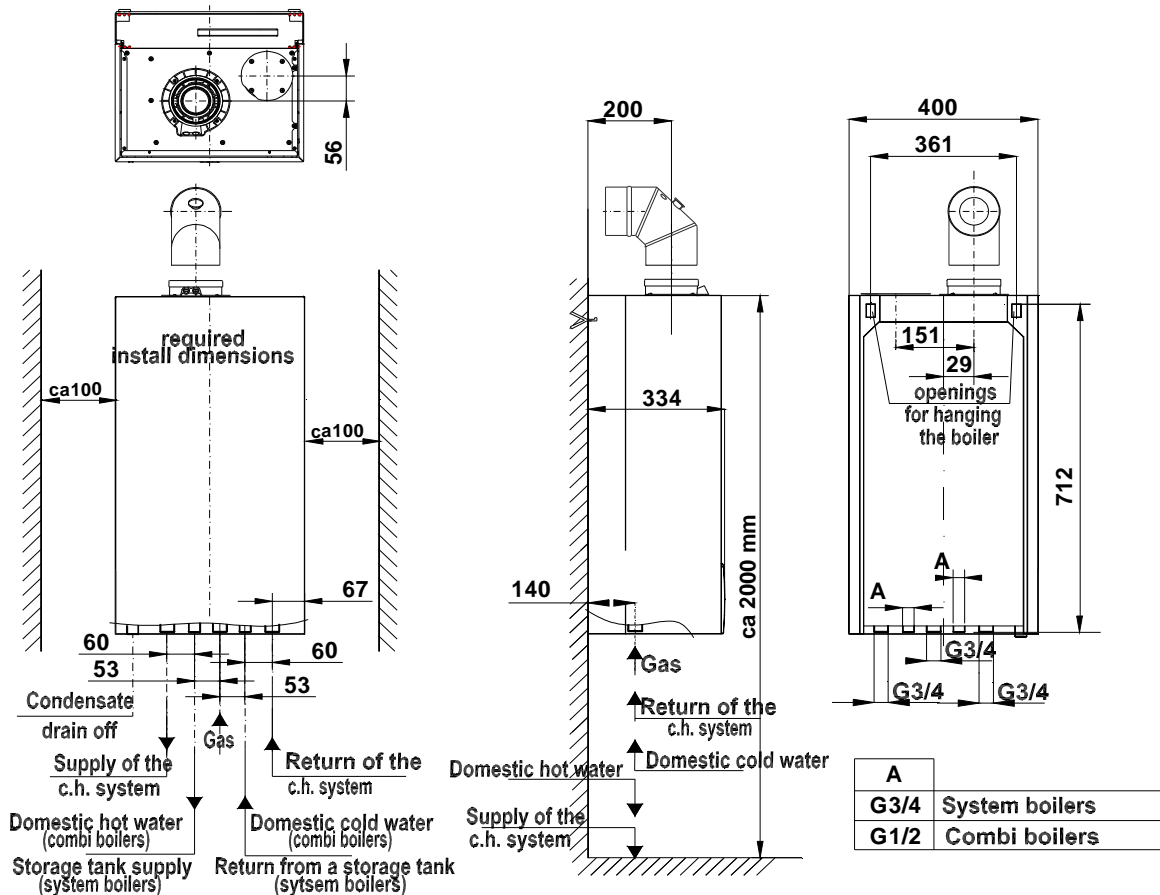

Fig. 3.3.1 Installation dimensions of boiler ECOCONDENS SILVER PLUS

3.4. Connection to the gas installation

Connect a gas supply pipe directly to the connector of the boiler gas unit using of connector subassembly no 0696.00.00.00 (in boiler equipment).

It is necessary to install a gas filter on the gas supply pipe. This filter is not included in the standard boiler equipment. The gas filter is necessary for a proper operation of a gas unit and a burner.

Install a cut-off valve on the gas pipe in an accessible place.

3.5. Connection of the boiler to a water system of central heating

- Power supply and return connectors of the central heating boiler should be screwed to the installation. Location of the connectors → Figure 3.3.1.

- **Install a water filter on a water return from central heating system (in front of the connection with the pump). The filter is not included in standard boiler equipment.**
- The central heating system should be thoroughly rinsed out before the boiler is connected.
- In the central heating system it is permitted to use as a heat carrier any antifreeze fluids which can be used in central heating systems.
- The cut-off valves needs to be installed between the boiler and central heating system so that the boiler could be dismantled without draining the system.
- Do not install any thermostatic valves on radiators in the room where the thermostat is installed. The temperature controller takes the control over the function of temperature and it cooperates with the boiler.
- On at least one of radiators of the central heating system there shouldn't be installed a thermostatic valve.
- It is recommended to lead out a water from a safety valve 0,3 MPa (3 bar) (item 25) to a floor drain by a tube or hose otherwise during the safety valve activation there is a risk of flooding a room what is excluded of producer's liability.

Selection of expansion vessel

Boilers ECOCONDENS SILVER PLUS are adjusted to be connected to a central heating system with the maximum capacity of 105 liters. The assembly to installation with larger capacity is acceptable only after applying an additional expansion vessel. A proper expansion vessel should be selected by the designer of central heating system.

Installation of expansion vessel should be made by an installation contractor in accordance with applicable regulations.

NOTICE! : Before installing the boiler thoroughly flush the central heating system to free it from any solid impurities.

It is recommended that after first start up of the boiler and heating up of the installation drain the water from the system to remove residues of pastes metallurgical and precautionary measures of heaters. These activities would benefit for the operation of the device, its parameters and components life.

After boiler installation:

- Fill the heating system with water by filling valve → item 22 Fig 2.2.1.1. for combi boiler. For system boiler install filling valve from the installation. Pressure in cold installation should amount 1,0 to 1,5 bar (indicated by manometer).
- Vent the installation of central heating and boiler;
- Check the tightness of boiler connections in central heating system.

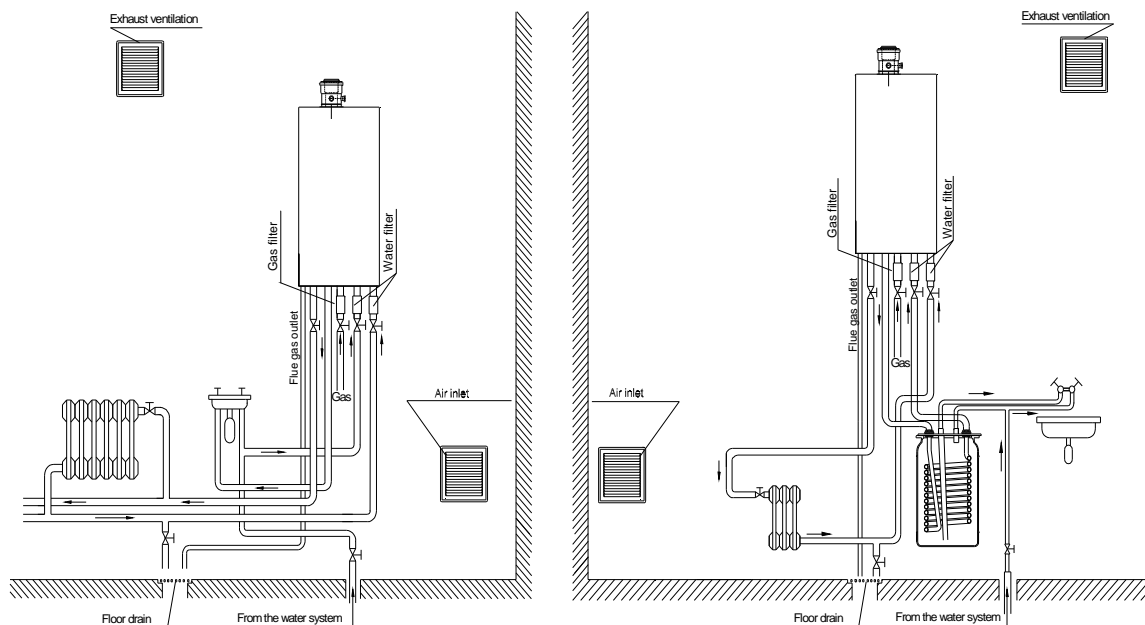

Fig. 3.5.1 Boilers installation requirements

3.5.2 System cleaning and water treatment for the C.H. filling.

Every component of C.H. system is threatened by limestone deposits, corrosion and other dangerous processes. Boiler is the most expensive part of C.H. system and it is necessary to protect its components like heat exchanger and other parts against harmful processes. Correct C.H. circuit preparation for using relies on making two operations: cleaning the CH system and treating the water that fills the system.

System cleaning

In new installation it is possible to find some remains of industrial process jak soldering and welding remains, flux, oil and grease residue among others. Older installations usually have products of corrosion in them. It necessary to clean up the systems with a water to remove the remains before boiler is mounted. Afterwards, system should be cleaned with appropriate chemicals. For example Cleaner F3 from Fernox in new installations. For old and contaminated systems it is best to use Cleaner F5). Afer that it is necessary to rinse the installation with water.

Water treatment to fill the system

For filling the system, it is recommended to use water with parameters: pH 6,5- 8,5, hardness < 10 ʒ (~ 18°F). Do not use demineralised or distilled water. To ensure protection against rocks despositing, corrosion, it is recommended to use a special inhibitor, for example Fernox Protector F1. Heat transfer fluid HP-5 or antifreeze liquid can also be used, for example Fernox Alpha 11. If the water hardness is very high, the HP-5 effectively reduces the risk of heat exchanger calcification.

Low-temperature circuits

In the low-temperature area, it is recommended to treat the water by using heat transfer fluid HP-5 or Fernox AF10 biocide.

Filtration technique

Additionally, in order to ensure the quality of operation heating system, it is recommended to mount a modern filters, which works on the principle of the magnetic and cyclone effect, for example Fernox TF1 filter.

Notice:

- method and amount of use specific products for system cleaning and water treatment should be in accordance to the product manufacturer's instruction.
- above steps should be made by the authorized installer or service technician.

3.6. Connection of the boiler to a domestic hot water system

It is recommended to install cut-off valves on a domestic hot water system what will enable easier maintenance and service.

It is recommended to install a water filter on the connection with the domestic water supply. This filter is not included in the standard boiler equipment.

3.7. Condensate outlet

Condensate formed during the combustion process must be drained according the following conditions:

- Installation of condensate drain must be made of corrosion-resistant material.
- Connection of draining the condensate cannot be blocked.
- To facilitate to drain the condensate through the flue gas all horizontal flue pipes must be installed with a fall of 3° (52mm / m).

3.8. Flue gas outlet

Condensate formed during the combustion process must be drained according the following conditions:

EcoCondens SILVER PLUS boilers could be installed as B-type appliances (where air needed for combustion is taken from the room where boiler is installed) or as C-type appliances (where air needed for combustion is taken from outside). C-type appliances could be divided as follows:

Depending on local regulations some types of installations might not be allowed. Always consult your local regulations before making flue-gas system project.

Before turning on the boiler check if flue-gas system is made according to the project and air- and flue ducts lengths are shorter than maximum lengths showed in tables 3.8... Make sure flue-gas system is tight.

After turning on the boiler check if it operates correctly. Also check combustion parameters by checking concentration of CO₂ and/or O₂ in flue-gas.

Ways of connecting the boiler to the air-flue gas system → Fig. 3.8...

To ensure proper functioning of the device use the appropriate wire size (diameter, maximum length, resistance on the knees), depending on the combustion system used. The dimensions of the wires should be adequately compatible as given in table. Resistance of flue gas flow on each elbow depending on the bending angle and related reduction of the maximum wire length are given in section 3.8.6.

Each system should be installed with the windproof outlet protecting against external factors.

For condensing boilers ECOCONDENS SILVER PLUS there are provided three types of flue gas-air systems: coaxial system Ø80/Ø125 and Ø60/Ø100 and 2 separate 2 x Ø80. It is possible to apply air-flue gas pipe made from polypropylene or stainless steel. The individual components of flue gas- air systems are given in table 7.1

NOTICE:

The boiler is factory adjusted for the coaxial exhaust system Ø60/100 of the maximum pipe length 3m + elbow. Settings O₂ – 5%. To use the other systems and longer pipes it is required to adjust the boiler as specified in point 4.2.

Coaxial reduction Ø60/Ø100 x Ø80/Ø125 shall be applied when using coaxial air-flue gas pipe Ø80/Ø125. Inspection T-piece shall be applied when using air-flue gas pipe made from stainless steel.

Condensing boilers SILVER PLUS meet the requirements to use in multi-storey air-flue gas systems LAS.

3.8.1. The ways of mounting adapters (elbows connection) to the boiler type

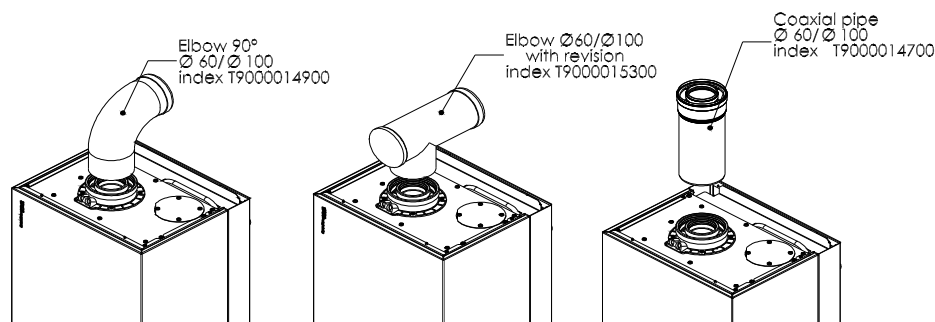

Coaxial system (air-flue gas pipe made from polypropylene)

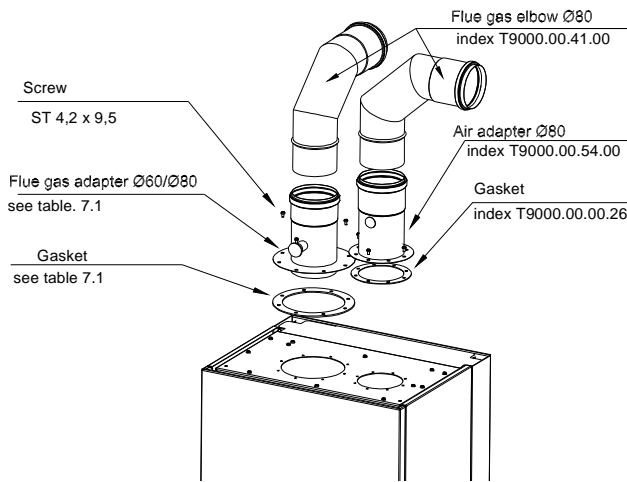

Separate system (air-flue gas pipe made from stainless steel)

3.8.2. Horizontal outlet of air- flue system through the wall or on the roof

Table 3.8.2.1

Type of boiler	Coaxial system Ø60/Ø100
ECOCONDENS SILVER PLUS -20	Maximum length of chimney flue $L_{max}=15$ m
ECOCONDENS SILVER PLUS -25	Maximum length of chimney flue $L_{max}=17$ m
ECOCONDENS SILVER PLUS -35	Maximum length of chimney flue $L_{max}=12$ m
Type of boiler	Coaxial system Ø80/Ø125
ECOCONDENS SILVER PLUS -20	Maximum length of chimney flue $L_{max}=25$ m
ECOCONDENS SILVER PLUS -25	Maximum length of chimney flue $L_{max}=25$ m
ECOCONDENS SILVER PLUS -35	Maximum length of chimney flue $L_{max}=20$ m

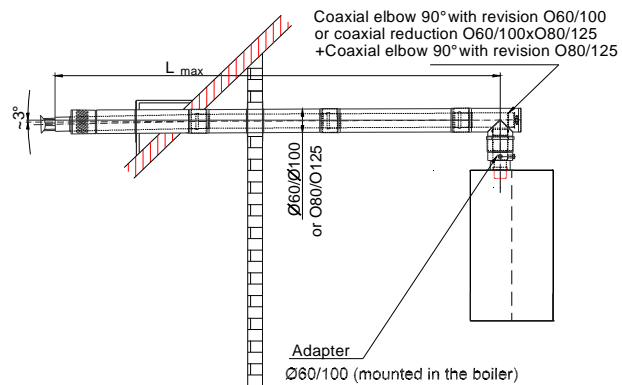
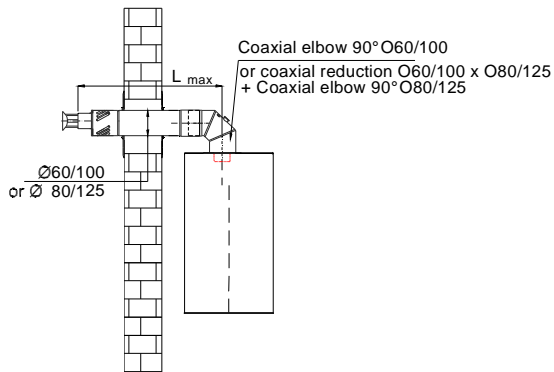

3.8.3 Vertical outlet of air- flue gas system through the roof

Table 3.8.3.1.

Type of boiler	Coaxial system Ø60/Ø100
ECOCONDENS SILVER PLUS -20	Maximum length of chimney flue $L_{max}=15$ m
ECOCONDENS SILVER PLUS -25	Maximum length of chimney flue $L_{max}=17$ m
ECOCONDENS SILVER PLUS -35	Maximum length of chimney flue $L_{max}=12$ m
Type of boiler	Coaxial system Ø80/Ø125
ECOCONDENS SILVER PLUS -20	Maximum length of chimney flue $L_{max}=25$ m
ECOCONDENS SILVER PLUS -25	Maximum length of chimney flue $L_{max}=25$ m
ECOCONDENS SILVER PLUS -35	Maximum length of chimney flue $L_{max}=20$ m

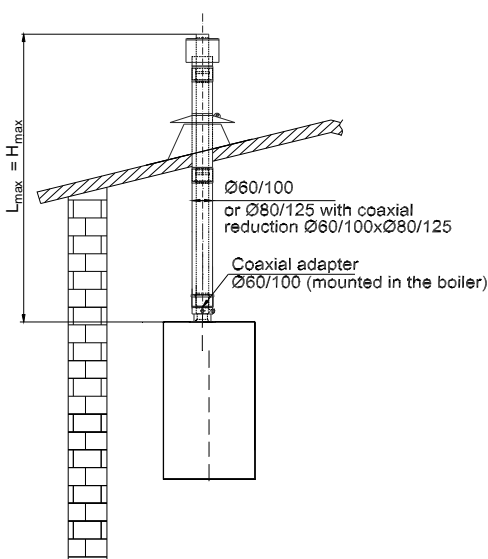

3.8.4 Connecting to a common chimney duct system, consisting of a duct for air inlet and flue gas outlet duct

Table 3.8.4.1.

	Type of boiler	Coaxial system Ø60/Ø100	
	ECOCONDENS SILVER PLUS -20	Maximum length of chimney flue L_{max}=15 m	
	ECOCONDENS SILVER PLUS -25	Maximum length of chimney flue L_{max}=17 m	
	ECOCONDENS SILVER PLUS -35	Maximum length of chimney flue L_{max}=12 m	
	Type of boiler	Coaxial system Ø80/Ø125	
	ECOCONDENS SILVER PLUS -20	Maximum length of chimney flue L_{max}=25 m	
	ECOCONDENS SILVER PLUS -25	Maximum length of chimney flue L_{max}=25 m	
	ECOCONDENS SILVER PLUS -35	Maximum length of chimney flue L_{max}=20 m	

3.8.5. Flue gas air outlet and air inlet by two separate tubes

To apply the steel two-pipe system should:

- Unscrew the top cover of the combustion chamber at point of connection of the air supply system to the boiler
- Retain a gasket existing under the cover
- In place of the removed cover screw the adapter (index T9000.00.54.00) sealing the connection with a gasket,
- In place of flue gas outlet after the dismantling of the coaxial adapter Ø60/Ø100 and reducing ring Ø60/Ø80 the adapter should be screwed (index T9000.01.11.00). Bottom part of the adapter should be inserted in the boiler flue gas outlet and the connection should be sealed by the gasket attached to the adapter

To apply the polypropylene two-pipe system should:

- Unscrew the top cover of the combustion chamber at point of connection of the air supply system to the boiler
- Disassemble coaxial adapter Ø60/Ø100 and reducing ring Ø60/Ø80
- Mount adapter set (index T9000.02.10.00)

Notice: The horizontal air tube should be mounted at an angle of ~ 3° (→ Figure 3.8.5.1) so that rain water that gets into the pipes would not flood the boiler and flowed outside the building.

Table 3.8.5.1.

	Type of boiler	Separate system Ø80 x Ø80
	ECOCONDENS SILVER PLUS -20	Maximum length of chimney flue H ₁ + H ₂ L_{max}=25 + 25 = 50 m
	ECOCONDENS SILVER PLUS -25	Maximum length of chimney flue H ₁ + H ₂ L_{max}=25 + 25 = 50 m
	ECOCONDENS SILVER PLUS -35	Maximum length of chimney flue H ₁ + H ₂ L_{max}=20 + 20 = 40 m

3.8.6 Reduction of the maximum length of the air-flue system by changing the flow direction

Reduction of the max length of the air-flue system by changing the flow direction		
15°	45°	90°
0.25m	0.5m	1m

3.9. Connection of additional devices

On the back of the controller there are two flaps under which there is access to electrical terminals.

To connect an additional device unscrew the appropriate flap, put the cable through the bushing in the flap and connect the ends of the wire to the correct terminals.

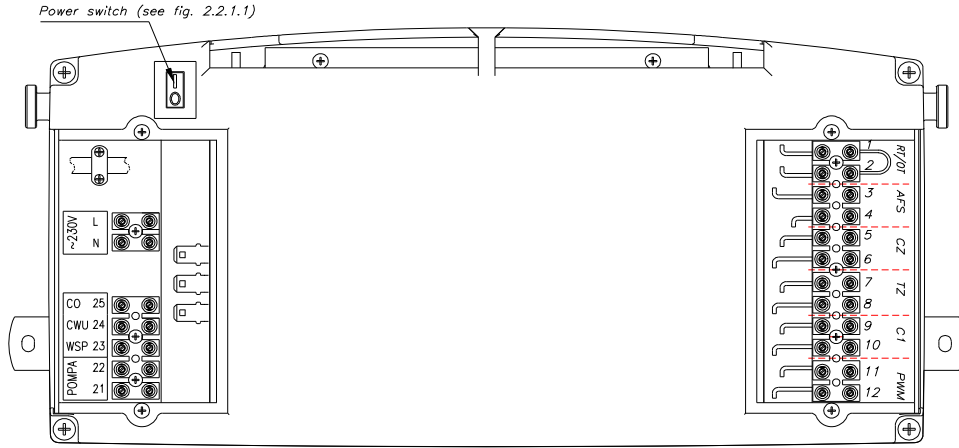

RT/OT – room temperature controller (red wire) **AFS** – outside temperature sensor (black wire)
in system boilers: CZ – tank temperature sensor **TZ**- tank time regulator
in boilers with PWM pump: PWM- PWM pump control **C1** – return heating water temperature sensor

Fig.3.9.1 Electrical terminals of controller - a back view

3.9.2 Connection of a room temperature regulator

3.9.2.1 Room regulator with contact.

The boiler has been designed to cooperate with a room temperature control unit which has got its own supply source and control contact free from potential. Connections must be made according to the instructions of regulator manufacturer. In order to connect the temperature thermostat to the boiler the appropriate length two-core wire is needed. It needs to be connected to terminals 1 and 2 (RT/OT) located under the right flap (→ Fig. 3.9.1) - previously separating the electrical bridge.

To connect room temperature regulator to the boiler we advise to contact a qualified person or AUTHORIZED INSTALLER.

3.10. Connecting the outside temperature sensor

To connect the outside temperature sensor use the 2 wire cable (2x0,5mm² 50m max) and connect it to terminals 3 and 4 (AFS) located under the right flap → Fig. 3.9.1.

Connection must be made in accordance with the instructions provided by the sensor manufacturer. It is the best to place the outside temperature sensor on the north wall of the building and it should not be exposed to direct sunlight.

4. BOILER ADJUSTMENT AND PRELIMINARY SETTING

4.1. Introductory remarks

Purchased boiler is factory adjusted according parameters for the type of gas that is provided on the rating plate and in the documentation of the boiler. Only AUTHORIZED FACTORY SERVICE can do any and parameter settings of the boiler if there is any need to change the parameters or to adjust the boiler to another type of gas.

4.2. Adjusting the boiler to combust another type of gas

The boiler can be adjusted to combust another type of gas but only for this one which the boiler is certified for. The types of gases are given on the rating plate - in the index designation:

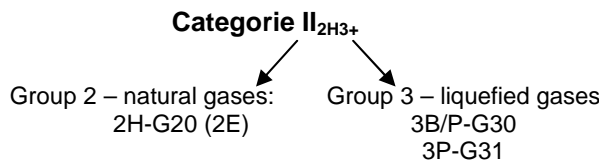

Example of completed label:

termet s.a		After adapting the boiler to combust another type of gas: <ul style="list-style-type: none"> • Cross out on a rating plate the type of gas to which the boiler was adapted by the manufacturer, • Write down the symbol of the gas, to which the boiler has been adjusted and the set heat load on the appropriate label that is attached bulk to the user manual. The entry must be written legibly and indelibly. • Label filled in as above should be stuck on the cover near rating plate.
Setting for the gas:	liquefied	
Gas symbol:	3B/P	
Gas pressure [mbar]	30	
Set the nominal heat load		
..... [kW]		

Adapting the boiler to combust another type of gas can be performed only by QUALIFIED SERVICE COMPANY. This operation is not included in the warranty repairs.

In order to perform above mentioned operations check if:

- the tightness of the gas system connections was checked after the boiler installation and it was confirmed with the signature and the stamp of the installer,
- the electrical installation was made in accordance with applicable regulations,
- the correctness of connections between the boiler and the chimney was checked and confirmed by a qualified chimney service.

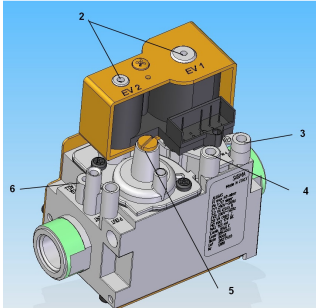

2. Gas valve coils EV1-EV2,
3. Measuring point of inlet gas pressure,
4. Measuring point of outlet gas pressure,
5. A minimum pressure adjustment screw, (→ Fig. 4.2.1)
6. A maximum pressure adjustment screw

Fig. 4.2.1 Gas valve

4.3. Boiler adjustment

Below described ways of regulation are applied only for replacement of the gas unit. All regulations must be based on the equipment listed in Table 4.3.2.1.

4.3.1. Gas flow regulation in the boiler (without using the flue gas analyzer)

Before proceeding to adjustment, activate the service function of the boiler in the following way:

- set the mode: WINTER; → p.5.3
- press the button twice
- on the display symbol flashes; left field shows fan rotation speed and max symbol placed over it, right field show C.H. temperature.,
- in time to 5 seconds press the button + for 2 sec.; after service function activation the symbol stops flashing,
- using the button "+" you can turn on maximum fan speed (defined by parameter P05),
- using the button "-" you can turn on minimum fan speed (defined by parameter P04),
- service function is activated for 10 min. Earlier termination - pressing the reset button.

Regulation of boilers with power 20kW, 25kW and 35kW	
Maximum power adjustment	Minimum power adjustment
<ul style="list-style-type: none"> • Set the maximum fan speed according to → 4.3.1 Check the gas flow rate on the gas meter for compliance with Table 4.3.2.1. If you need to change the gas flow turn the screw - pos. 6 (→ Fig. 4.2.1). • Turn the screw to the left to increase the flow, turn the screw to the right to decrease it. Set value of flow you can read on the gas meter. 	<ul style="list-style-type: none"> • Set the minimum fan speed according to → 4.3.1 • During boiler operation measure the gas inlet pressure on the measuring point (→ item.3 Fig. 4.2.1.) The value of pressure depending on the type of gas are given in Table 4.3.2.1, • Remove the cap from the measuring point number 5 (→ Fig. 4.2.1.) • Using the adjusting screw number 5 (→ Fig. 4.2.1) set the minimum gas flow according to the values given in Table 4.3.2.1. • Turn the screw to the right to increase the flow, turn the screw to the left to decrease it.

4.3.2. Adjustment of the boiler with a gas analyzer

Regulation of boilers with power 20kW, 25kW and 35kW	
Maximum power adjustment	Minimum power adjustment
<ul style="list-style-type: none"> • Set the maximum fan speed according to → 4.3.1 • During boiler operation measure the gas inlet pressure on the measuring point (→ item.3 Fig. 4.2.1.) The value of pressure depending on the type of gas are given in Table 4.3.2.1, • Connect the flue gas analyzer • Using the adjusting screw number 6 (→ Fig. 4.2.1) set the gas flow to obtain the required composition of the flue gas listed in Table 4.3.2.1. 	<ul style="list-style-type: none"> • Set the minimum fan speed according to → 4.3.1 • During boiler operation measure the gas inlet pressure on the measuring point (→ item.3 Fig. 4.2.1.) The value of pressure depending on the type of gas are given in Table 4.3.2.1, • Connect the flue gas analyzer • Remove the cap from the measuring point number 5 (→ Fig. 4.2.1.) • Using the adjusting screw number 5 (→ Fig. 4.2.1) set the gas flow to obtain the required composition of the flue gas listed in Table 4.3.2.1.

NOTICE:

Check the settings for the max and min. gas flow.

If the adjustment is complete, close all measuring points, then check tightness and re-seal them.

The data specified for gases at normal conditions (15°C, pressure 1013 mbar), having regard to boiler efficiency -97.4.

Table 4.3.2.1. The control parameters of the boiler

		Min power			Max power					
		ECOCONDENS SILVER PLUS			ECOCONDENS SILVER PLUS					
		20	25	35	20		25		35	
Gas type	Inlet pressure (mbar)	P04=12	P04=12	P04=12	P01= 25 P05=77		P01= 25 P05=76		P01= 25 P05=83	
		The content of CO2 in the flue gas [%]			The content of CO2 in the flue gas [%]					
		10.0 ^{±0.2}			9.5 ^{±0.2}					
		Gas flow rate [l/min]**			Gas flow rate [l/min]**					
2H-G20, 2E-G20	20 ÷ 25	4.8 ^{+0.5}	6.9 ^{+0.5}	7.3 ^{+0.5}	35.3 ⁺¹	44.3 ⁺¹	42.6 ⁺¹	53.1 ⁺¹	61.9 ⁺¹	71.4 ⁺¹
Gas type	Inlet pressure (mbar)	Min power			Max power					
		ECOCONDENS SILVER PLUS			ECOCONDENS SILVER PLUS					
		20	25	35	20		25		35	
		P04=12	P04=12	P04=12	P01= 35 P05=66		P01= 35 P05=64		P01= 40 P05=63	
The content of CO2 in the flue gas [%]			The content of CO2 in the flue gas [%]							
11.0 ^{+0.5}			11.0 ^{+0.5}							
Gas flow rate [l/min]**			Gas flow rate [l/min]**							
3B/P-G30	37	1.4 ^{+0.5}	2.0 ^{+0.5}	2.1 ^{+0.5}	10.2 ⁺¹	12.8 ⁺¹	12.3 ⁺¹	15.3 ⁺¹	17.9 ⁺¹	20.5 ⁺¹
Gas type	Inlet pressure (mbar)	Min power			Max power					
		ECOCONDENS SILVER PLUS			ECOCONDENS SILVER PLUS					
		20	25	35	20		25		35	
		P04=12	P04=12	P04=12	P01= 40 P05=74		P01= 40 P05=72		P01= 40 P05=77	
The content of CO2 in the flue gas [%]			The content of CO2 in the flue gas [%]							
11.0 ^{+0.5}			11.0 ^{+0.5}							
Gas flow rate [l/min]**			Gas flow rate [l/min]**							
3P-G31	37	1.8 ^{+0.5}	2.6 ^{+0.5}	2.8 ^{+0.5}	13.4 ⁺¹	16.9 ⁺¹	16.3 ⁺¹	20.3 ⁺¹	25.6 ⁺¹	27.0 ⁺¹

*During adjustment the boiler with removed cover of the chamber consider to increase amount of CO₂ given in table 0.2 ÷ 0.3%

**Listed in the table value of gas flow are indicative. Their value depends on the actual content of CO₂ in the flue gas.

***If the system boiler is connected to domestic water tank, set the parameter P02 in accordance with power of tank's coil.

4.4. Fan characteristics

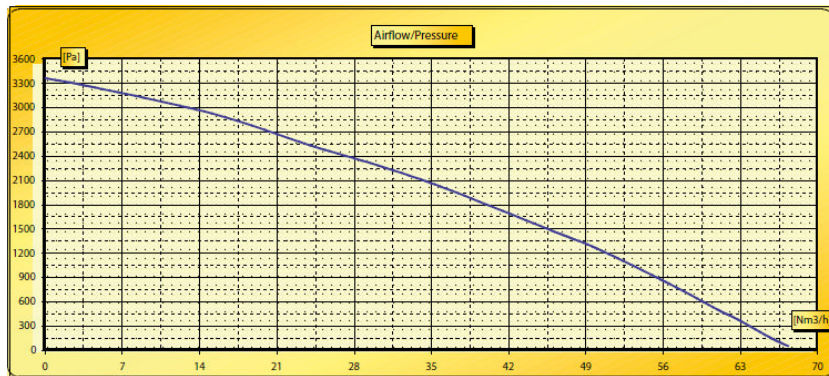

Fig.4.4.1. Characteristics of the fan- type NG40m

5. STARTUP AND OPERATION OF THE BOILER

5.1. Initial startup of the boiler

After installing the boiler, checking the accuracy and tightness of its connections and preparing for operation in accordance to this instruction manual and applicable regulations first commissioning and user training for boiler operation and safety devices may be done only by AUTHORISED SERVICE COMPANY.

5.2. Inclusion and operation

All boiler functions are performed by the boiler electronic control panel. Changing the operating mode and settings is done done by 4 buttons. Current state of the boiler is shown on the LCD display.

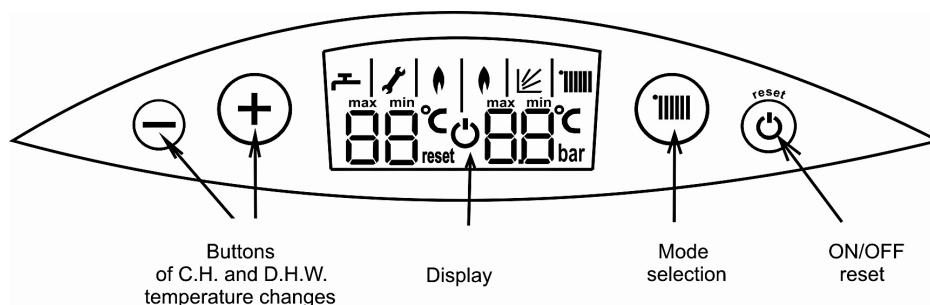

Fig. 5.2.1. Control panel





- Check the pump (→ item.6.1.6),
- Connect the boiler to the electrical mains,
- Open the gas valve and water valves,
- Turn on controller by using an electric switch, available at the bottom of the boiler through a hole in the bottom tray (→ Fig. 2.2.1.1 and 3.9.1)
- Wait until the boilers enters auto-diagnosis mode.
- Set the mode WINTER or SUMMER (→ item.5.3)

The turning on of the boiler in the heating season

- Set the desired temperature of the heating water using buttons:{+ / - CH} in the range of 40°C to 80°C
- The spark generator will cause ignition of gas outflowing from the burner.
- Set the desired water temperature using buttons (→pos.6) in the range of 30°C to 60°C.

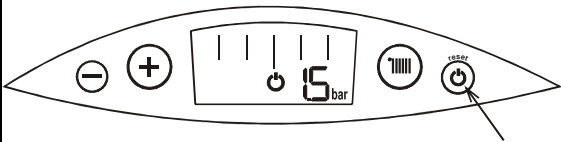
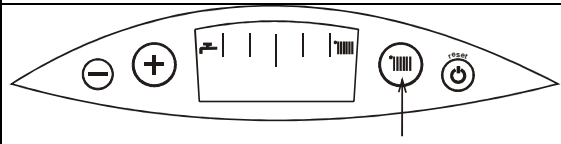

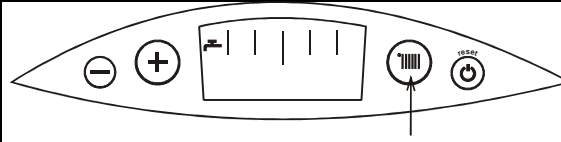



Remember! The priority is always to obtain domestic hot water during operation of the boiler
When the room temperature controller is connected, set desired room temperature on the controller.

5.3. Operating modes of the controller

Mode	Display	Changing the operating mode	Performed functions
STAND-BY		To turn on /turn off the controller press the RESET button for about 2 seconds	<ul style="list-style-type: none"> • anti-freezing function: the boiler is switched on when the boiler water temp. drops below 8°C and heats the water as long as the temperature reaches 20°C • protection against pump blocking (pump is switched on 180 sec every 24 hours) • 3-way valve blocking protection (valve is switched on 15sec. every 48 hours)
WINTER		Press button  for about 1 second - changing the operating mode to mode WINTER	<ul style="list-style-type: none"> • CH and DHW heating, • Service function, • Anti-legionella function - active only for boilers with tanks
SUMMER		Press button  for about 1 second - changing the operating mode to mode SUMMER	<ul style="list-style-type: none"> • D.H.W. heating, • Anti-legionella function - active only for boilers with tanks,

5.4. Signalization of operation states and diagnosis

When the controller starts the operation after power loss (restart) the display shows a flashing symbol . The symbol disappears if the control system will be ready to accept user commands.

Symbol on the display	Signalization	Remarks
	BURNER IS OPERATING	Left flame: DHW mode operation. Right flame: CH mode operation.
	WEATHER FUNCTION IS ACTIVE	During the CH setting changing, instead of the temperature the value of Kt parameter is displayed for example: 5.2 without symbol: °C.
	CHANGING C.H. SETTING	During changing the CH setting symbol  flashes with the set value.
	CHANGING DHW SETTING	During changing the DHW temperature setting symbol  flashes with the set value.
MAX	MAXIMUM SETTINGS	Maximum setting value is reached. If you exit the setting changes mode the symbol is blanked.
MIN	MINIMUM SETTINGS	Minimum setting value is reached. If you exit the setting changes mode the symbol is blanked.
L3	PAUSE IN C.H. HEATING	Displayed L3 symbol means a pause in C.H. heating in time determined by parameter P25 (default 3 min) for heat exchanger cooling when C.H. temperature exceeds the hysteresis value (parameter P20, default 5°C) of the setting. Pump operation will be stopped if the following conditions are met: <ul style="list-style-type: none"> • no signal „HEAT” from room temperature regulator, • heating water temperature dropped by 5°C from the the set value • 180 sec. have passed after burner switching off.

	<ul style="list-style-type: none"> • SERVICE FUNCTION • PARAMETERS CHANGING • SYGNALISATION OF EMERGENCY SITUATIONS 	The symbol can indicate different situations. It appears: <ul style="list-style-type: none"> • when service function is active → 4.3.1 • during controller configuration → 5.7.1 • during signalisation of emergency situations → 5.8.2
RESET	SWITCHING OFF THE BOILER WITH LOCK	After removing the cause of the failure to restart the boiler operation, use the reset button. Anti-freezing function is performed only by pump operation.
Po	SUPPORT THE VENTING OF HEATING SYSTEM	Venting procedure can be stopped manually at any time by pressing the buttons '+' and '-' at the same time.

5.4.1. Signalisation of the start of heating in CH or DHW system

At the moment of starting the heating in the CH system or DHW system, the display shows the set temperature of CH or DHW for 4 seconds, also diode at symbol of temperature and the symbol of circuit is flashing.

5.4.2. Signalisation of anti-freezing function operation in STAND BY mode

When the operation of anti-freezing function in the CH system in standby mode is started - the pressure value on the display is replaced by a value of temperature in the central heating circuit. When the anti-freezing function operation starts in DHW circuit - display shows the temperature value in DHW circuit.

5.4.3. Displaying the water pressure in CH installation

When the boiler is set to STAND BY mode, the water pressure in the heating system is displayed on the display continuously. In the SUMMER or WINTER mode temporary pressure display follows after a short pressing the **reset** button.

5.4.4. Displaying parameters

To display additional parameters (in different mode than STAND-BY), press reset button.

1. At first, display shows the C.H. water pressure for 2.5 sec.,

2. Next, for another 2.5 sec.:

- when C.H. circuit is heated and during standing in WINTER mode, on the left field display shows "In" and on right field the value of return C.H. temperature. If the sensor is not connected, display shows "--",

- when D.H.W. circuit is heated and during standing in SUMMER mode, on the left field display shows „Ch" and on right field the value of C.H. temperaute,

3. Next, for another 2.5 sec. on the left field display shows „Pr" and on right field the value of % pump flow (for traditional pump display shows "--") ,

4. At the end, for 2.5 sec. on the left field display shows „Fr" and on right field the value of % fan flow.

Display stops showing parameters automatically or after another press reset button.

5.4.5 DHW heating blockade indicator for one-function boilers.

One - function boilers do not realize heating water in the tank and displays the symbol '-' on the left field of the display when the timer TZ- tank terminals are open (see p. 3.9).

5.4.6 Support the venting of heating system

Each time, after voltage supply and after completion of the fan calibration procedure, the controller automatically starts a special procedure to support venting of the heating system. It consists of successive six cycles: switching on the pump for 15 sec. and switching off the pump for 15 sec. alternately in CH and DHW circuit. Lock of heating is established during the procedure. Activity of the procedure is signaled by Po code, key symbol and pressure of CH indication. Control system activates the standard pump cycle in CH circulation for a specified period after the procedure (180 sec.). After pressure increasing, venting procedure is activated with lock of heating at the time of its implementation if during the operation of the device, CH pressure drops below the allowed lower bound (which will be signaled by E9 code alternately with pressure indication).

5.5. Changing the CH or DHW temperature settings

5.5.1. Temperature settings in CH circuit

1) After a short pressing button  controller enters the CH settings mode. Flashing CH temperature is displayed on the right side of the display.

2) Buttons + / - enable to change the value of CH setting.

Completion of the operation changes mode is done automatically after

5 seconds of inactivity, after pressing the button  or after pressing the **reset** button.

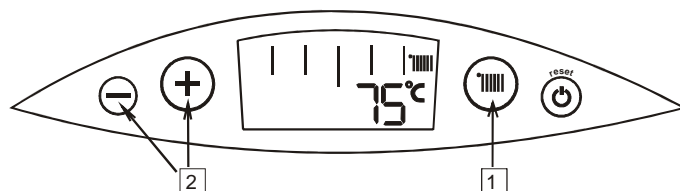

5.5.1.1. Changing value of the Kt coefficient

When the weather function is active (outside temperature sensor is connected), during changing the C.H. setting, instead of the temperature the value of Kt parameter is displayed for example.: 5.2 without °C.

5.5.1.2 Changing a parameter ECO

If the boiler is equipped with a pump with adjustable speed and is set to ECO mode (p.2.4.5) the values of ECO can be changed. In WINTER operation mode, hold for 2 seconds the + / - . On the left side you will see blinking symbol 'Ec' and on the right side the blinking value ECO eg. 0.5. By the buttons + / - the value of the parameter can be change. Exit of parameter change mode is automatically after 3 seconds of inactivity or after pushing button reset.

5.5.2 Temperature settings in DHW circuit

1) A short pressing buttons **+ / -** causes the activation of the D.H.W. settings mode. The value of D.H.W. temperature is flashing on the left side of the display.

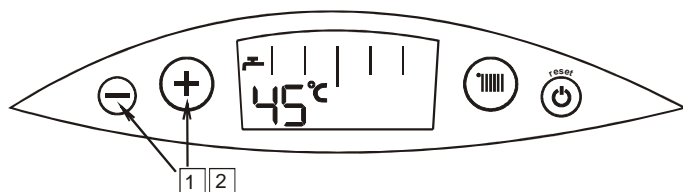

2) Buttons **+ / -** enable to change the value of D.H.W. setting.

Completion of the operation changes mode is done automatically after 5 seconds of inactivity or after pressing the **reset**.

NOTICE:

1. In the case of system boilers, reducing the setting DHW results in stopping the water heating in the tank (below the value indicated on the display by symbol "MIN"). In the left field of display you can see the symbol „—“. To switch on again the function of heating water in the tank it is necessary to increase the setting to the minimum value or higher.

2. When the controller is in STAND BY mode, service function mode, or in state of emergency blockade then the setting of C.H. and D.H.W. cannot be changed.

5.6. Controller configuration – boiler parameters setting

It is possible to change the following parameters of the boiler through the procedure of programming:

	Name	Values	Factory default values	Remarks
P01	Start power	0 ÷ 99 (100 steps from min to max)	→ see Table 4.3.2.1	-
P02	Max power for DHW	0 ÷ 99 (100 steps from min to max)		-
P03	Max power for CH	0 ÷ 99 (100 steps from min to max)		-
P04	Minimum speed limit	1000 ÷ 2000 [rotations/min] (1 step = 100 rotations/min)		-
P05	Maximum speed limit	2500 ÷ 9500 [rotations/min] (1 step = 100 rotations/min)		-
P06	Type of boiler selection	1 ÷ 2 (1 – system boiler, 2 – combi boiler)	Depending on boiler type	Parameter is visible when the CM clamp is removed
P07	Type of CH circuit	1 – closed	1	Boiler adapted for closed central heating system
P08	Type of heating	0 / 1 (0 – standard heating, 1 – floor heating)	0	-
P09	Type of CH pressure transducer	0 / 1 (0 – type: 0,5 ÷ 3,5 V; Uz=18V, 1 – type: 0,5 ÷ 2,5 V; z=5V;	1	Transducer connection: 0 – socket M10 1 – socketM12
P10	"Anti-legionella" mode	0 / 1 (0 – manual mode, 1 – automatic mode)	0	important only in case of boilers with water tanks
P11	The number of pulses per rotation	1/2/3/4 [pulses / rotation]	2	-
P12	Type of pump	0 / 1 (0 – standard, 1 – with PWM signal)	Depending on boiler type	-
P13	ΔT for pump with PWM signal	5 ÷ 25 °C	6	Parameter is visible when P12=1 and P15=0 and P07=1
P14	Min pump flow	15 ÷ 99%	50	Parameter is visible for P12=1 and P07=1
P15	ECO mode	0 / 1 (1 – ON, 0 – OFF)	0	Parameter is visible for P12=1 and P07=1
P16	a time when a boiler is working with max CH power which is set by parameter P17	0÷5 min	0	
P17	value of max CH power when a boiler works for a specified by parameter P16 period	0÷25%	10	Parameter is visible when P16 > 0
P18	Max speed limit for modulating pump in CH mode	25 ÷ 99 %	99	Parameter is visible when P12=1
P19	Max speed limit for modulating pump in DHW mode (if P6=1)	25 ÷ 99 %	99	Parameter is visible when P12=1 and P6=1
P20	Hysteresis for the condition of switching off at work in CH circuit	0 ÷ 10	5	
P21	CH temperature during heating the DHW in tank (if P6=1)	70 ÷ 89	75	Parameter is visible when P6=1
P22	The value of the parallel displacement of the heating curve of weather regulator	0 ÷ 20	0	Parameter visible for P26=1 or 2
P23	Fan type selection	0 ÷ 1 (0 – FIME, HONEYWELL FPE4200A; 1 – SIT NG40)	1	
P24	Startup power maintaining time during work in CH circuit	2 ÷ 30 sec	20	





P25	L3 pump overrun time	3 ÷ 60 min	3	
P26	Weather-compensation regulator mode	0 ÷ 2 (0-off, 1 – with room regulator, 2–autonomic, without room regulator)	1	
P27	Maximum ambient temperature below which boiler could resume operation	10 ÷ 21 °C	18	Parameter visible for P26=2
P28	Nighttime water temperature decrease	0 ÷ 20 °C	5	Parameter visible for P26=2

NOTICE:

Some of the parameters may not be visible in the programming mode, if the clamp on the control board CM UNI-02 is shorted. To access the parameters, turn off the power, remove the CM clamp and re-power the device. After

5.6.1. Programming Mode entering

To activate the programming mode:

1. Set the working mode: STANDBY (→ p.5.3)
2. Turn off the boiler power.
3. Turn on the boiler power again. Wait until the flashing symbol  disappears from the screen .
4. Press and hold **reset** together with  for over 4sec .
5. The display shows parameter number and symbol  displayed by constant light.
6. Release buttons.
7. Using **+ / -** select the desired parameter to change.
8. By pressing  button it is possible to edit the selected parameter. Change of the value is possible using the **+ / -** buttons
 - for P1 and P3 parameter boiler will be activated with desired power of CH
 - for P2 parameter boiler will be activated with desired power of DHW if the flow sensor of DHW will work.
 - after the completion of the gas ignition process the burner power will be the same as the displayed value
9. Changed value is approved with  button; to cancel the change use the **reset** button.

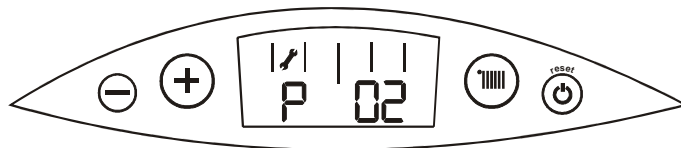

Recording parameters and exit the programming mode - hold down the reset button for about 2 seconds, or automatically after a set period of inactivity.

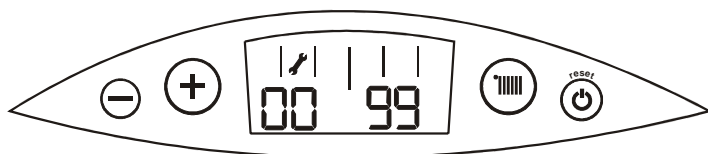
**5.7. Pause in boiler operation**

- leave the boiler connected to power supply,
- leave the gas valve and water valve of CH open,
- set the mode on STAND BY (→ section 5.3)
- In such conditions the controller of the boiler has a protective function described in point 5.3 - "Performed functions"

If You decide to discontinue use of the boiler for a long time you should:

- set the mode on STAND BY (→ section 5.3)
- drain the water system of the boiler and also CH system if there is possibility of freezing, by using drain valve → pos. 33 Fig 2.2.1.1 and 2.2.1.2
- close the water and gas valves and disconnect the boiler from power supply.

NOTICE: In a winter time (because of the risk of freezing water in the system) the disconnection the boiler from electrical system is forbidden (if there is still water in the water system of the boiler).

5.8. Diagnosis**5.8.1. Signalisation of error codes during the emergency procedures implementation**

During the implementation of emergency procedures a constant error code is displayed consisting of letter "E" and two digits. Symbols  and „RESET" are blanked. If the emergency procedure is successfully completed the boiler will automatically return to normal operation and the error code disappears. The negative result of the emergency procedure causes emergency **switching off with the blockade**.

5.8.2. Signalisation of error codes in emergency situations without locking

In the emergency situation without a blockade, the flashing symbol  and the error code consisting of letter "E" and two digits are displayed. Symbol „RESET" is blanked.

In particular cases the error code can be displayed alternately with the temperature or pressure value in the CH circuit. After removing the cause of the failure the boiler will automatically return to normal operation and the error code disappears.

5.8.3. Signalisation of emergency switching off with locking





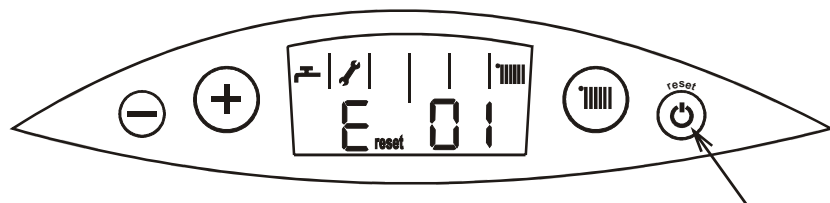



Emergency lock is indicated by displaying the error code and flashing symbols  and „RESET". Return to normal operation is possible after removing the cause of failure and after press the reset button.



If the boiler will continue to block we advise you to contact AUTHORISED SERVICE COMPANY.



The figure above shows an example of display with error code E 01 with symbols **reset** and 

5.8.4. Error list

Error code	Error cause	Way of error removing
E 01	No flame on the burner: 3 automatic reignition attempts are taken (for LPG - 2 attempts). Each attempt is preceded by 30 sec. break for ventilation of the boiler. After the failure of attempts follows: switching off the boiler with blockade, displaying the symbol E RESET 01	The boiler is in the process of gas ignition tests and will return to normal operation.
 E _{reset} 01	No flame on the burner: Turning off the boiler with blockade after unsuccessful attempts of gas ignition. The reason of failure may be: 1. Lack of gas. ----- 2. Erroneous connection to power source (phase detection)	Check if the gas cocks are opened and if the gas reaches the boiler. Press reset button To fix: - turn off power - switch lines of power cable
 E _{reset} 02	The water temperature in the gas-water heat exchanger exceeds 95 °C. The boiler is turned off with a blockade.	Press reset button
 E _{reset} 03	The flue gas temperature has exceeded the permitted value. The one-time thermal fuse was burned off and the boiler was switched off with blockade.	Call Authorized Service Company
 E 04	Damage in the circuit of NTC sensor of heating water temperature. The burner is turned off.	Call Authorized Service Company
 E _{reset} 06	Failure in the electronic system of the boiler. The burner is turned off	Call Authorized Service Company
 E 07	Failure of the measuring system of fan speed or failure of the fan.	Call Authorized Service Company
 E 08	Failure of water pressure transducer (in CH system) The burner is turned off, the pump operates for 180 sec.	Call Authorized Service Company
 E 09	Incorrect pressure in CH system. if: P > 2.8 bar - controller turns off the burner, the pump operates for 180 sec, P < 0.5 bar - controller turns off the burner, the pump operates for 180 sec, if: P ≤ 2.5 bar - return to the normal operation. P ≥ 0.5 bar - return to the normal operation.	When the pressure in CH is higher than 2.8 bar some water should be drained from installation. The pressure may be too high if there has been too high initial pressure in the system or if there occurred damage in the compression vessel. If the pressure in the CH system is below 0.5 bar you should fill in the system with water and check for leaks
 E 10	Failure in the circuit of NTC temperature sensor (in DHW system). The burner is turned off.	Call Authorized Service Company

	<p>Overrun of the maximum number of consecutive emergency situations E1 after earlier detection of flame.</p>	<p>Press reset button</p>
	<p>Missing or damaged sensor heating water (return) during the water heating in the CH circuit with active mode of PWM pump. Error code is displayed alternately with the temperature of heating water leaving the boiler.</p>	<p>Call Authorized Service Company</p>

6. MAINTENANCE, INSPECTIONS, CHECKING OF THE OPERATION

6.1. Inspecton and maintenance

The boiler should be regularly serviced and subjected to maintenance.
At least once a year it is recommended to perform a service and it should be reviewed before heating season.
 All service and maintenance works should be performed by an Authorized Person. Only original parts should be used for boiler repairs.
 At every service and maintenance works the tightness of the gas units and gas installation and correctness of the protective systems should be checked. The warranty does not cover above mentioned operations.

6.1.1. Maintenance of the combustion chamber, burner, electrode.

The interior of the combustion chamber, burner surface and the electrode should be checked by visual inspection: the contaminated burner and the interior of the combustion chamber may be cleaned with a brush made of plastic

- visible on the surface of the burner gaps and deformations disqualify burner - replace the burner,
- clean the electrode with a plastic brush,
- deformed electrode should be replaced,
- check the condition of insulator of electrode,
- clean dirty insulator,
- insulator with visible damages should be replaced.

Note! Dirty burner and the interior of the combustion chamber mean that the boiler regulation must be done.

In order to get into the combustion chamber, burner and electrode:

- close the gas valve,
- unscrew the front part of the combustion chamber,
- remove the wires from the end of the electrode,
- remove the cover fixing screw of flue gas-water heat exchanger,
- remove the cover of heat exchanger,
- assemble in reverse order.

Note: Tightening torque for the nuts of the burner door should be 5 Nm (+1/0 Nm).

Pay attention not to damage the seals:

- check the tightness of connections.

- 5** Fan
- 10** Electrode
- 11** Burner
- 13** Heat exchanger
- 29** Siphon

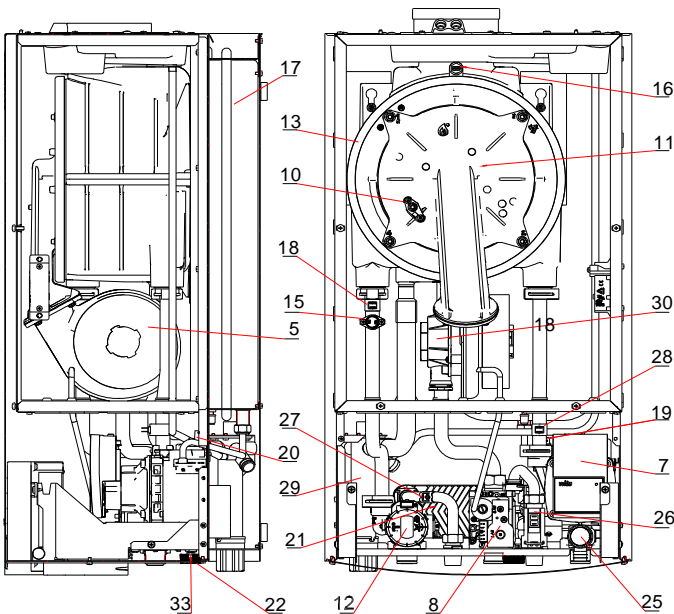

6.1.2. Cleaning the condensate siphon

Condensate siphon should be inspected at least twice a year. If you need to purge:

- unscrew siphon,
- clean the siphon of any dirt,
- tighten the siphon.

Check the patency of the siphon (for example blow the tube which drains the condensate).

In case of difficulty in clearing the siphon it should be removed from the boiler and cleaned with the strong stream of water.

To avoid the possibility of leakage of flue gas through a siphon until the condensation of the condensate in it (flooding) there is a possibility of flooding the siphon by pouring a little water.

6.1.3. The pressure in the expansion vessel

The pressure in the expansion vessel

Check the pressure in the expansion vessel (→item 17) using pressure meter (for example automotive) connecting it to the fan on the vessel. The value given in Table 2.2.2.

If there is any need to adjust the pressure in the expansion vessel using the pump (for example a car pump)

Note: When checking the pressure in the expansion vessel the central heating water pressure in the inside system of the boiler must be zero.

6.1.4. Maintenance of the flue water-water heat exchanger, item.21

The heat exchanger design provides turbulent water flow over the entire heat exchanger surface minimizing contamination of internal surfaces of the exchanger. But when there are favorable conditions for the formation of solid impurities they must be removed. To do this select one of the methods recommended by the manufacturers of heat exchangers such as Alfa Laval or SWEP.

6.1.5. Checking the temperature sensors

(→ Table 6.1.5.1.)

- NTC sensor of C.H. water, D.H.W. and central heating return

- Remove the sleeves from the NTC sensors,
- Measure the sensor resistance

- outside temperature sensor

- Disconnect the sensor cable from the terminals under the flap of control panel

- Measure the sensor resistance

- tank temperature sensor

- Disconnect the sensor cable from the terminals under the flap of control panel

- Measure the sensor resistance

Temperature [°C]	NTC (DHW) and NTC (CH) sensor resistance, NTC tank sensor and temperature sensor resistance Sensor: $\beta=3977$
-10	55218 [Ω] ±0.75%
0	32624 [Ω] ±0.75%
10	19897 [Ω] ±0.75%
20	12.480 [Ω] ±0.75%
30	8.060 [Ω] ±0.75%
60	2.490 [Ω] ±0.75%
80	1.210 [Ω] ±0.75%

Table 6.1.5.1 Resistance of NTC sensor, outside temperature sensor and tank NTC sensor, depending on the temperature

6.1.6. Checking the water pump operation

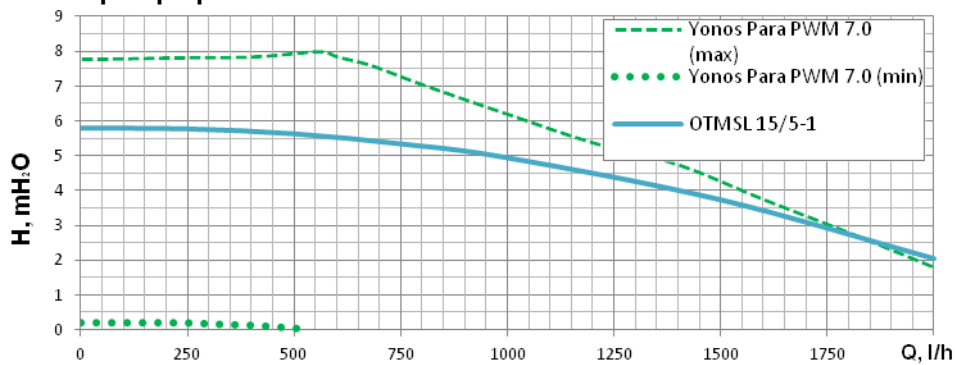

Fig. 6.1.6.1 Pump characteristic

The check should be done at the first start the boiler and when the following events occur:

- the pump is not working after turning on (does not raise the pressure in the C.H. system)
- start the pump impeller by hand (not applicable to PWM pumps).

6.1.7. Ionisation current measurement

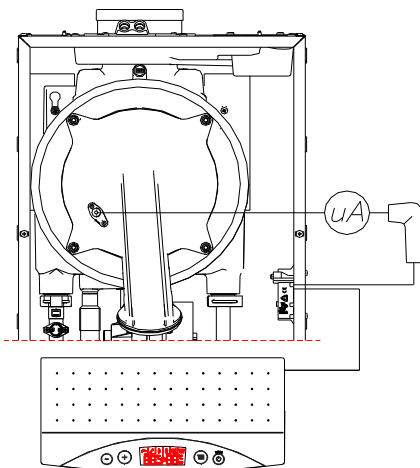

Fig. 6.1.7.1 Wiring diagram for the ionisation current measurement

To measure ionisation current, perform the following actions:

- put boiler in STAND-BY mode
- disconnect the cable from the electrode
- connect an ammeter (µA range) according to the above diagram
- turn on the boiler in C.H. mode
- read the value of ionisation current

Note: The value of ionisation current should be equal or higher than 2µA.

6.2. Replacing a damaged control board in the control panel

If the control board need to be replaced follow the installation instructions attached to each board devoted as spare part.

Parameters of components for boilers ECOCONDENS SILVER PLUS 20,25,35

Item on the scheme	Name	Parameters	Supply voltage from the controller
5	Fan NG40m	Power: 75 W (max)	230V AC
7	Pump Yonos Para PWM	Power: 45W	230V AC
8	Gas unit SIT SIGMA 848	Valve coil resistance: 3-4 EV1: 0,9 kΩ 1-3 EV2: 6,4 kΩ	230V AC
18	NTC sensor of CH water temperature	10K@25°C β=3977	SELV
19	Heating water pressure transducer	The output voltage: 0,5 V to 2,5 V (0 bar - 4 bar)	5V DC
26	Domestic water flow sensor	pin	SELV
27	NTC sensor of DHW water temperature	10K@25°C β=3977	SELV
28	NTC sensor of CH water temperature -return	10K@25°C β=3977	SELV
42	NTC sensor of outdoor temperature	10K@25°C β=3977	SELV
15	Temperature limiter 95°C	pin	SELV
16	Thermal fuse	pin	SELV
12	3-way valve		230V AC

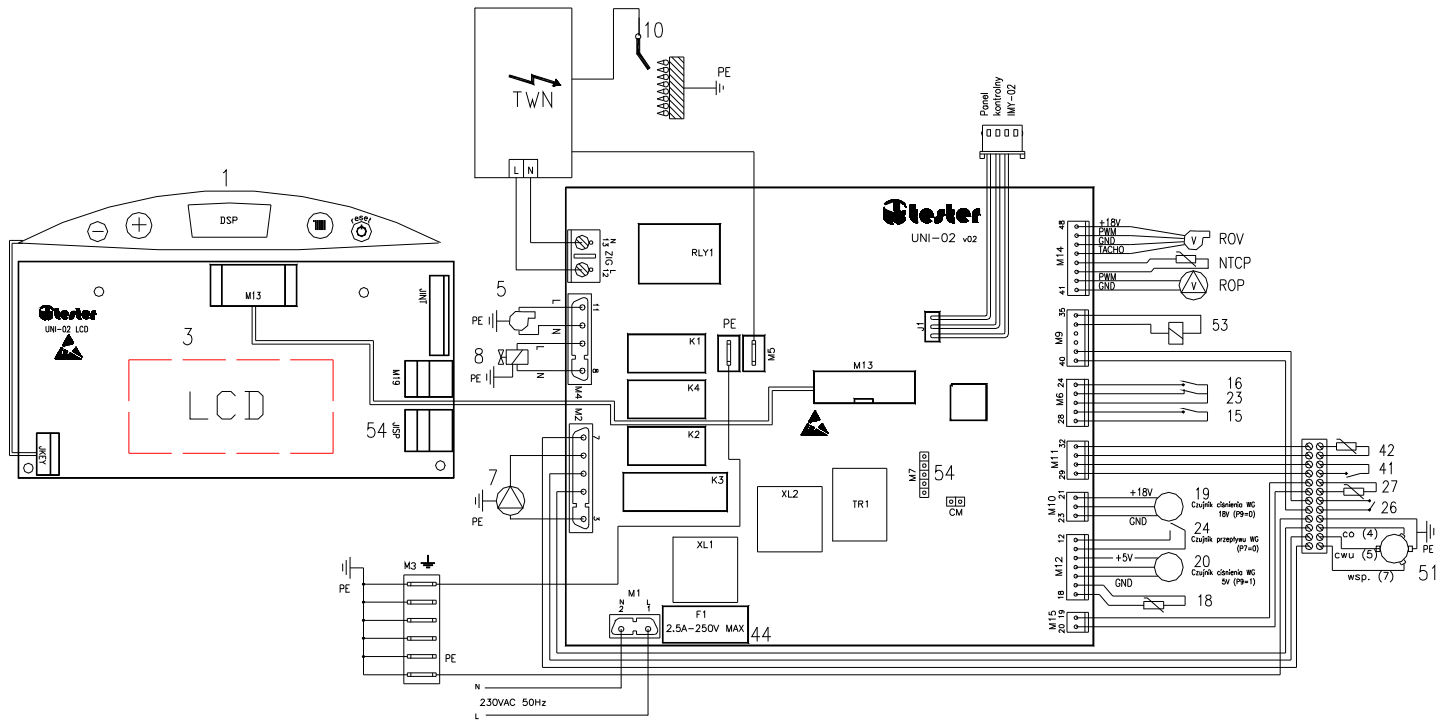

System boiler

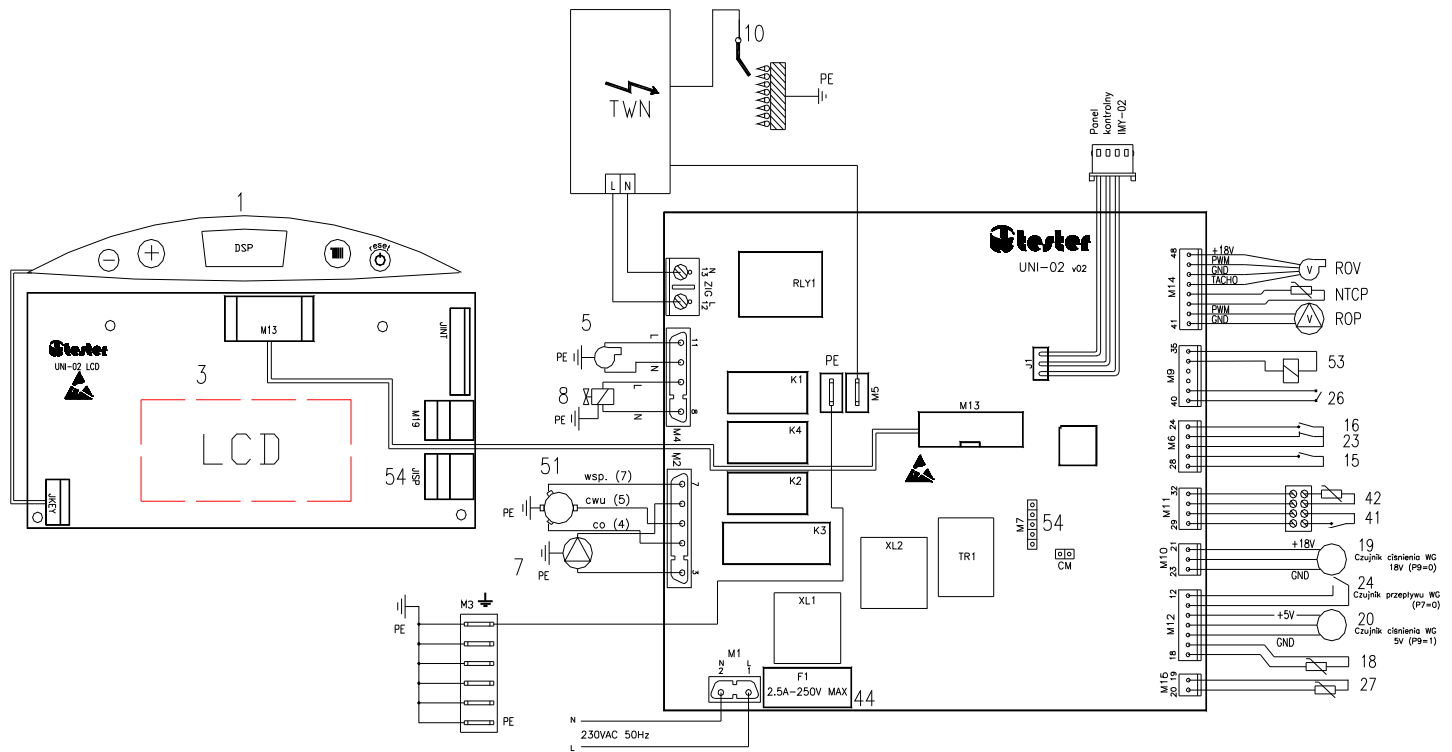

Combi boiler

No	Description	No	Description	No	Description	No	Description
1	User interface (foil)	10	Ignition/Flame control electrode	26	D.H.W. flow sensor / Tank time regulator	54	Connector "In System Programming"- microprocessor programming
3	User interface (control board)	15	Heating water temperature limiter	27	NTC sensor of D.H.W. temperature	P1	Button OFF / RESET
5	Fan	16	Fumes temperature limiter	41	Room temperature regulator	P2	Buttons SET
7	Pump	18	NTC sensor of heating water temperature	42	NTC sensor of outside temperature	P3	Button +
8	Gas unit	20	Heating water pressure sensor 5V	44	Fuse	P4	Button -
9	Flame control electrode	24	Heating water flow sensor	51	3-way valve	CM	Blockade of extended mode of control system configuration
M3	Connector coupling PE	M5	Flame control connector	JKEY	User interface connector (foil)	ROP	Pump speed regulator
TWN	Spark generator	NTCP	NTC sensor of heating water temperature (return)	M13	User interface connector	ROV	Fan speed regulator

Fig.6.2.1. Schematic diagram of the electrical connections

6.3. The maintenance operations to be performed by the user

User should:

- clean the water filter periodically, preferably before the heating season (should be replaced when used),
- clean the domestic water filter also in case of finding decreasing flow,
- refill the central heating system with the water,
- deaerate the central heating system and the boiler,
- periodically clean the boiler cover with the water with detergent (avoid cleaners that cause scratches).

6.4. Range of technical maintenance performed by service company

- Maintenance of the combustion chamber, burner, ignition electrode and ionization electrode
- Cleaning the condensate siphon
- The pressure in the expansion tank
- Maintenance of the water-water heat exchanger
- Check the temperature sensors (→ table)
- Replacing a damaged control board in the control panel
- Checking the water pump operation according section. 6.1.6.

7. BOILER EQUIPMENT

In table 7.1 there is placed a list of parts required for installation of the boiler, its proper operation and for enhancement the comfort of usage of the product. The following items are available for purchase together with the boiler or are supplied with the boiler.

Table 7.1

No.	Name	Drawing number Type Code	INDEX	Quantity	Refers to the boiler:	Remarks
1	2	3		4	5	6
1.	Hook for wood 8 x 70			2	ECOCONDENS SILVER PLUS	In boiler equipment. Put in the package of the boiler
2.	Sparing sleeve			2		
3.	Adhesive spacer EPDM	1780.00.00.49		4		
4.	Tank NTC sensor	0960.00.10.00		1	ECOCONDENS SILVER PLUS (system boilers)	
5.	Subassembly of gas connector	0696.00.00.00		1 set	ECOCONDENS SILVER PLUS	
PURCHASE RECOMMENDED TO IMPROVE COMFORT OF THE BOILER USAGE						
6.	Room temperature regulator		T9448.00.00.00 or T9449.11.00.00 or T9449.10.00.00	1	ECOCONDENS SILVER PLUS	Not included in boiler equipment
7.	Outside temperature sensor	WKC0566.00.00.00 or WKC0567.00.00.00		1		
PURCHASE NECESSARY TO ENSURE THE PROPER OPERATION OF THE BOILER						
8.	Gas filter			1	ECOCONDENS SILVER PLUS	Not included in boiler equipment
9.	Heating water filter			1		
10.	Domestic water filter			1		
PURCHASE NECESSARY TO ENSURE THE PROPER OPERATION OF THE FLUE GAS-AIR SYSTEM OF THE BOILER (PP system)						
No.	Name	Drawing number Type Code	INDEX	Quantity	Refers to the boiler:	Remarks
Flue gas-air system – coaxial Ø80 / Ø125 (Fig. 3.8.2.1.)						
1	Coaxial elbow ø80/ø125 90°		T9000015000	1	ECOCONDENS SILVER PLUS	Not included in boiler equipment
	Coaxial reduction ø60/ø100 x ø80/ø125		T9000016700	1		
	Elements of the system (according to the installation design)					
Flue gas-air system – coaxial Ø60 / Ø100 (Fig. 3.8.2.1.)						
2	Coaxial elbow ø60/ø100 90°		T9000014900	1	ECOCONDENS SILVER PLUS	Not included in boiler equipment
	Elements of the system (according to the installation design)			1 set		
Flue gas-air system – coaxial Ø80 / Ø125 (Fig. 3.8.2.1.)						
3	Coaxial elbow ø80/ø125 90° with revision		T9000015400	1	ECOCONDENS SILVER PLUS	Not included in boiler equipment
	Coaxial reduction ø60/ø100 x ø80/ø125		T9000016700	1		
	Elements of the system (according to the installation design)			1 set		
Flue gas-air system – coaxial Ø60 / Ø100 (Fig. 3.8.2.1.)						
4	Coaxial elbow ø60/ø100 90° with revision		T9000015300	1	ECOCONDENS SILVER PLUS	Not included in boiler equipment
	Elements of the system (according to the installation design)			1 set		
Flue gas-air system – coaxial Ø80 / Ø125 (Fig. 3.8.3.1.)						
5	Coaxial reduction ø60/ø100 x ø80/ø125		T9000016700	1	ECOCONDENS SILVER PLUS	Not included in boiler equipment
	Elements of the system (according to the installation design)			1 set		
Flue gas-air system – coaxial Ø60 / Ø100 (Fig. 3.8.3.1.)						
6	Elements of the system (according to the installation design)					
Flue gas-air system – coaxial Ø80 / Ø125 (Fig. 3.8.4.1.)						
7	Coaxial reduction ø60/ø100 x ø80/ø125		T9000016700	1	ECOCONDENS SILVER PLUS	Not included in boiler equipment
	Coaxial elbow ø80/ø125 90° with revision		T9000015400	1		
	Elbow 90° ø80		T9000017400	1		
	Support bracket for elbows 90°		T9000017900			
	Elements of the system (according to the installation design)			1 set		
Flue gas-air system – coaxial Ø60 / Ø100 (Fig. 3.8.4.1.)						
8	Coaxial elbow ø60/ø100 90°		T9000014900	2	ECOCONDENS SILVER PLUS	Not included in boiler equipment
	Support bracket for elbows 90° ø60		T9000017910	1		
	Elements of the system (according to the installation design)			1 set		
Flue gas-air system with – separate pipes Ø80 x Ø80 (Fig.3.8.5.1)						
9	Adapter set ø80 for separate system		T9000021000	1	ECOCONDENS SILVER PLUS	Not included in boiler equipment
	Elements of the system ø80 (according to the installation design)			1 set		
PURCHASE NECESSARY TO ENSURE THE PROPER OPERATION OF THE FLUE GAS-AIR SYSTEM OF THE BOILER (steel system)						
No.	Name	Drawing number Type Code	INDEX	Quantity	Refers to the boiler:	Remarks
Flue gas-air system – coaxial Ø80 / Ø125 (Fig. 3.8.2.1.)						
1	Coaxial reduction ø60/ø100 x ø80/ø125		T9000016700	1	ECOCONDENS SILVER PLUS	Not included in boiler equipment
	Coaxial elbow ø80/ø125 90°		T9000001200	1		
	Elements of the system (according to the installation design)					

Flue gas-air system – coaxial Ø60 / Ø100 (Fig. 3.8.2.1.)						
2	Coaxial elbow ø60/ø100 90°		T9000001100	1	ECOCONDENS SILVER PLUS	Not included in boiler equipment
	Elements of the system (according to the installation design)			1 set		
Flue gas-air system – coaxial Ø80 / Ø125 (Fig. 3.8.2.1.)						
3	Coaxial T-piece ø80/ø125 90° with revision		T90000 01400	1	ECOCONDENS SILVER PLUS	Not included in boiler equipment
	Coaxial reduction ø60/ø100 x ø80/ø125		T9000016700	1		
	Elements of the system (according to the installation design)			1 set		
Flue gas-air system – coaxial Ø60 / Ø100 (Fig. 3.8.2.1.)						
4	Coaxial T-piece ø60/ø100 90° with revision		T90000 01300	1	ECOCONDENS SILVER PLUS	Not included in boiler equipment
	Elements of the system (according to the installation design)			1 set		
Flue gas-air system – coaxial Ø80 / Ø125 (Fig. 3.8.3.1.)						
5	Coaxial reduction ø60/ø100 x ø80/ø125		T9000016700	1	ECOCONDENS SILVER PLUS	Not included in boiler equipment
	Coaxial inspection T-piece		T9000007300	1		
	Elements of the system (according to the installation design)			1 set		
Flue gas-air system – coaxial Ø60 / Ø100 (Fig. 3.8.3.1.)						
6	Coaxial inspection T-piece		T9000007200	1	ECOCONDENS SILVER PLUS	Not included in boiler equipment
	Elements of the system (according to the installation design)					
Flue gas-air system – coaxial Ø80 / Ø125 (Fig. 3.8.4.1.)						
7	Coaxial reduction ø60/ø100 x ø80/ø125		T9000016700	1	ECOCONDENS SILVER PLUS	Not included in boiler equipment
	Coaxial T-piece ø80/ø125 90° with revision		T90000 01400	1		
	Coaxial elbow ø80/ø125 90° with support bracket		T9000001000	1		
	Elements of the system (according to the installation design)			1 set		
Flue gas-air system – coaxial Ø60 / Ø100 (Fig. 3.8.4.1.)						
8	Coaxial T-piece ø60/ø100 90° with revision		T90000 01300	1	ECOCONDENS SILVER PLUS	Not included in boiler equipment
	Coaxial elbow ø60/ø100 90° with support bracket		T9000000900	1		
	Elements of the system (according to the installation design)			1 set		
Flue gas-air system with separate conductors Ø80 x Ø80 (Fig.3.8.5.1)						
9	Flue adapter ø80		T9000011100	1	ECOCONDENS SILVER PLUS	Not included in boiler equipment
	Air adapter ø80	ADP 503/80	T9000005400	1		
	Elbow 90°	KS 121/80	T9000004100	1		
	Elements of the system ø80 (according to the installation design)			1 set		

termet

ul.Długa 13, 50-160 Świebodzice POLAND
Service Department tel. +48 (74) 854-04-46, fax. +48 (74) 854-05-42

www.termet.com.pl
termet@termet.com.pl
serwis@termet.com.pl
market@termet.com.pl